

Karboxx is hand made in Italy



karboxx srl
Via Cornaré, 12 - Basalghelle
31040 Mansué (TV)
Italy

light, more light
karboxx

BLONDE /

Design Massimiliano Mornati

Il concept di Blonde si basa su elementi quali versatilità, fantasia, finiture, che possono essere scelti e decisi dal designer per personalizzare e caratterizzare ogni singolo progetto.

Una forma trapezoidale, dal gusto postindustriale forse "radical chic" in grado di dipingere ed illuminare lo spazio.

L'alluminio viene verniciato con la finitura desiderata dal designer oppure scegliendo tra l'effetto cemento, ruggine, cromo nero lucido, bronzo spazzolato o il bianco.

Anche la lunghezza può essere personalizzabile fino ad un massimo di 5 metri.

La sorgente luminosa LED, diretta ed indiretta, con funzione dimmer, garantisce un ottimo comfort visivo per ogni esigenza progettuale.

Das Leuchtkonzept Blonde basiert auf Elementen wie Vielseitigkeit, Fantasie und Materialien, die vom Designer ausgewählt und bestimmt werden, um jedes einzelne Projekt personalisieren zu können. Eine Trapezform, durch postindustrielles Design geprägt, die den Raum prägt und erhellt.

Der Aluminiumkörper wird mit der vom Projektleiter gewünschten Ausführung verarbeitet. Standardmäßig stehen die Ausführungen „Beton-Effekt“, Rost, Chrom schwarz glänzend, Bronze gebürstet oder weiß zur Wahl. Auch die Lampengröße kann bis zu einer maximalen Länge von 5 Metern an die Kundenbedürfnisse angepasst werden. Die mit Dimmer ausgestattete LED-Lichtquelle, direkt und indirekt, gewährleistet einen hervorragenden Sichtkomfort in allen Raumsituationen

Blonde concept rests on versatility, creativity and finishes elements that can be chosen by designers and architects in order to customize and mark out every single project. A trapezoidal shape, with a postindustrial taste, paints and lights up the space. The aluminium could be painted both with a finish required by the designer and with cement, curtain, chrome polish black, brushed bronze and white. Furthermore also the length could be customized till a maximum of 5 meters. The LED lamp, direct or not, with dimmer optional, assures a perfect visual comfort for every designing need.

Le concept de Blonde est basé sur différentes éléments comme la versatilité, la fantaisie, les finitions qui peuvent être choisi par le designer en moyen de personnaliser chaque projet.

Une forme trapézoïdale de gout post industrielle, probablement "radical chic", capable de peindre et éclairer l'espace. L'aluminium verni avec la finition à choix de la part du designer ou en choisissant entre l'effet béton, rouille, chromé noir brillant, bronzé brossé ou blanc. La longueur aussi est à choix jusqu'à 5 mètres.

La source LED, directe et indirecte avec dimmer garantie un confort de haute qualité pour chaque exigence.

BLONDE /

Design Massimiliano Mornati

	MISURE / DIMENSIONS		COLORI / COLOURS		SORGENTI LUMINOSE / LIGHT SOURCES
	CM.	INCHES			
BLONDE 85	86X15X10	33.9X5.9X3.9			LED 110-240V - 2700K (3000K - 4000K On Demand)
29SP32DW			Bianca / White		DIMMERABILE: ALL IN ONE - DALI + PUSH DIMMER + 1-10V
29SP32D(T-N-E)			Corten(T) - Ottone Bronzato(N) - Cemento(E) / Corten(T) - Bronzed Brass(N) - Concrete(E)		44W - LUCE DIRETTA - DIRECT LIGHT - 4000 Lumen
29SP32DM			Cromo Nero Lucido / Black Chrome		
29SP31DW			Bianca / White		64W - LUCE DIRETTA+INDIRETTA - DIRECT/INDIRECT LIGHT - 5750 Lumen
29SP31D(T-N-E)			Corten(T) - Ottone Bronzato(N) - Cemento(E) / Corten(T) - Bronzed Brass(N) - Concrete(E)		
29SP31DM			Cromo Nero Lucido / Black Chrome		
BLONDE 125	126X15X10	49.6X5.9X3.9			64W - LUCE DIRETTA - DIRECT LIGHT - 6000 Lumen
29SP22DW			Bianca / White		
29SP22D(T-N-E)			Corten(T) - Ottone Bronzato(N) - Cemento(E) / Corten(T) - Bronzed Brass(N) - Concrete(E)		94W - LUCE DIRETTA+INDIRETTA - DIRECT/INDIRECT LIGHT - 8750 Lumen
29SP22DM			Cromo Nero Lucido / Black Chrome		
29SP21DW			Bianca / White		
29SP21D(T-N-E)			Corten(T) - Ottone Bronzato(N) - Cemento(E) / Corten(T) - Bronzed Brass(N) - Concrete(E)		
29SP21DM			Cromo Nero Lucido / Black Chrome		
BLONDE 165	166X15X10	65.4X5.9X3.9			84W - LUCE DIRETTA - DIRECT LIGHT - 8000 Lumen
29SP12DW			Bianca / White		
29SP12D(T-N-E)			Corten(T) - Ottone Bronzato(N) - Cemento(E) / Corten(T) - Bronzed Brass(N) - Concrete(E)		124W - LUCE DIRETTA+INDIRETTA - DIRECT/INDIRECT LIGHT - 11750 Lumen
29SP12DM			Cromo Nero Lucido / Black Chrome		
29SP11DW			Bianca / White		
29SP11D(T-N-E)			Corten(T) - Ottone Bronzato(N) - Cemento(E) / Corten(T) - Bronzed Brass(N) - Concrete(E)		
29SP11DM			Cromo Nero Lucido / Black Chrome		
BLONDE 245	246X15X10	96.9X5.9X3.9	On Demand		On demand
BLONDE 325	326X15X10	128.4X5.9X3.9	On Demand		On demand
BLONDE 405	406X15X10	159.8X5.9X3.9	On Demand		On demand
OPZIONI/OPTIONS					
Lunghezza personalizzabile fino ad un max di 5 mt / Length customized maximum 5 mt					

CERTIFICAZIONI/CERTIFICATIONS

CE IP 20 CLASSE 1

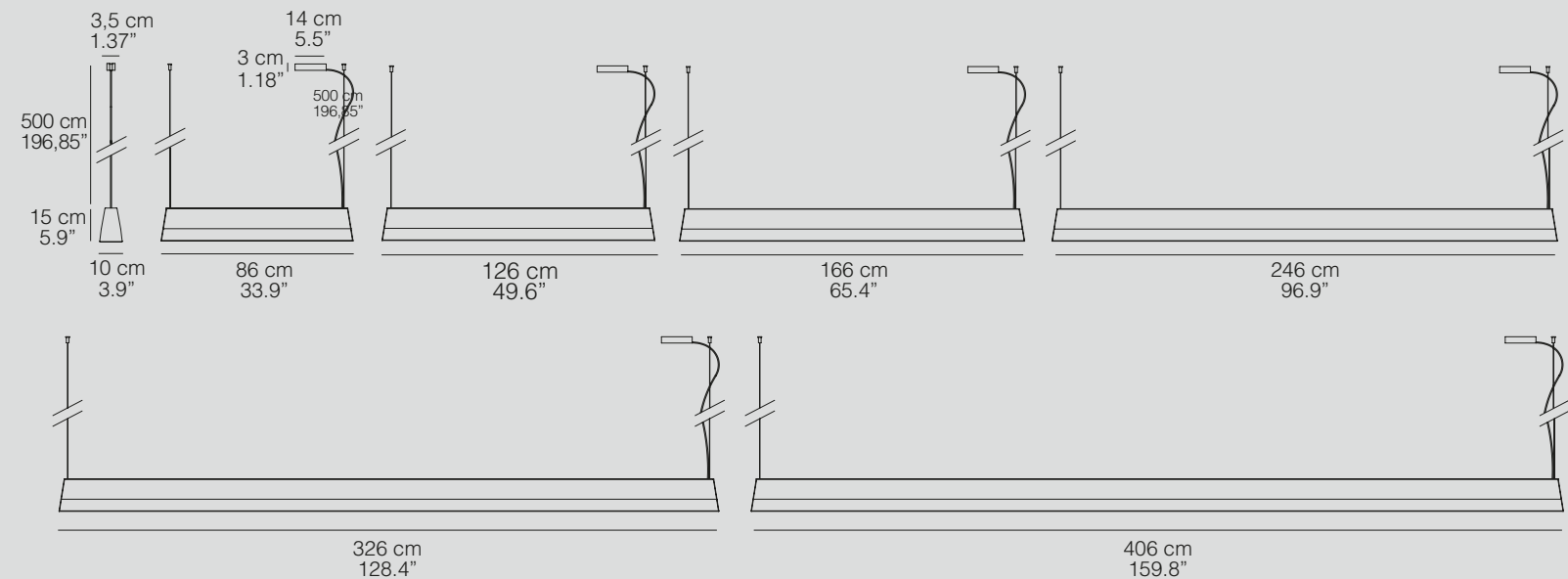

BIANCO
WHITE



29SP31(2)DW
29SP21(2)DW
29SP11(2)DW

CEMENTO
CONCRETE



29SP31(2)DE
29SP21(2)DE
29SP11(2)DE

CROMO NERO LUCIDO
BLACK CHROME



29SP31(2)DM
29SP21(2)DM
29SP11(2)DM

OTTONE BRONZATO
BRONZED BRASS

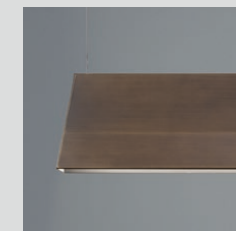

29SP31(2)DN
29SP21(2)DN
29SP11(2)DN

CORTEN



29SP31(2)DT
29SP21(2)DT
29SP11(2)DT

ROSONE
CEILING ROSE



MASSIMILIANO MORNATI

Como 1970, si laurea in architettura a Milano nel 1998, dopo esperienze in studi di architettura a Rotterdam, Berlino e Milano inizia la sua attività di progettista nei campi dell'architettura, dell'allestimento e del disegno del prodotto continuando il suo impegno nel disegno industriale.

Como 1970, graduated in Architecture in Milan 1998, after gaining experience in architects' studios in Rotterdam, Berlin and Milan he began his activity as an industrial designer.

Sospensione Cemento / Suspended Concrete



Sospensione Cromo Nero Lucido / Suspended Black Chrome



Sospensione Bianca / Suspended White