

# STYLE CULTURE SINCE 1967



beltá®

FRAJUMAR®

**Interview with Mr. Francisco Juan Martínez, founder, and sons:  
Francisco, Jorge and Carlos, current managing team of the Company.**

*Entrevista a Francisco Juan Martínez fundador en 1967 y a sus hijos  
Francisco, Jorge y Carlos, actual equipo directivo de la compañía.*

Entrevue avec Francisco Juan Martínez, fondateur en 1967 et son fils  
Francisco, Jorge et Carlos, actuelle équipe de gestion de la société.

**STYLE CULTURE SINCE 1967**  
The Home Collection

beltá   
FRAJUMAR 

# PAST, PRESENT AND FUTURE

PASADO, PRESENTE Y FUTURO / PASSÉ, PRÉSENT ET FUTUR



.Francisco Juan Martínez.

## How did all start? What pushed you to establish the company?

When writing the history of a company, it is easy to fall into the rhetoric of the literature. In the reconstruction of its origins, it is easy to idealize and create the character, but a company is not a person: is the result of the tenacity, combined with an innate ability in business. A mixture of intuition, of will and much work and why not, even a bit of luck. The early seventies saw, with the development of the internal market, how small and medium-sized enterprises were getting strong. Many of them were limited to the styling, very few changed their production techniques. Particularly in this scene I felt that there was a need to modernize, that there was room for a change. I as a manufacturer had the experience and decided to contribute with the changes the time was calling for. It was an instinctive gesture at that time.

## Is it difficult to maintain nowadays the same philosophy when you started?

From the moment that the transformation began in the company, the philosophy of the Group began to evolve through different stages. Beltá & Frajumar moves in a very sensitive area: the emotional, as the design line, and that is made with the same passion, the same attention to detail as always, but adding every year new proposals, innovation of cutting-edge and timeless style, this will become the joy of the final customer, even after several years. Furniture speaking of us, for home, office or hotel contract.

## Which is your today’s satisfaction?

*“Three children, a big company. Sometimes my wife and myself look at it. Who would have thought that we had done all these things? “.*” This is the only moment of emotional weakness by Francisco, the father in the ‘balance’ of his life, his family and the Belta & Frajumar family, the company he founded back in the 1960s. A moment of emotion compensated with the joy generated by the idea that their children were in charge of the company as in a relay race that every day becomes more and more difficult, but to see that they are able and they have been willing to choose a philosophy of life which is the interrelationship between work and family.

.Francisco L. Juan Ortiz.

## Why this catalogue?

“To demonstrate the ability of spinning into the environment of Belta & Frajumar the networking of artisanal and industrial excellence. Capacity that has made possible to develop product lines, manufactured here, complex and original, with great attention to detail, able to meet the demands of an international audience, which as we know, is increasingly demanding. The search for quality is a key element for us and it is perceived by the market giving us confidence. Thanks to this, we also were able to put in place a strategy dedicated to the contract: able to design, build and equip custom projects, “one of a kind”. We also have international interior designers and try to add our value either in the product or service. Our structure and organization is the key to what we are today.”

.Carlos L. Juan Ortiz.

## Which is the product or product family that better represents your company?

Today I would say that our company, rather than a specific product is searching above all to communicate a brand, a way of interpreting environments, offering customers a system to be able to customize their homes. Among all the products, it is not more than a product or a line that represents us. Our designs don’t follow trends, are made to be timeless. Models should be timeless, not only as a wear-resistant material but for its aesthetics; those who live in the House, in fact, do not have to get tired soon of what they have and must be convinced of their choice, even after some time.

.Jorge Juan Ortiz.

## Which are the future goals? What is and especially what will be the role of Belta & Frajumar in the current scenario, during the transformation of the relationship between design, business and customers?

Belta & Frajumar is today undergoing through great transformation. And not only, to start with the obvious, the new showroom of 1200 square meters, which has become the meeting point for the Hospitality Design, but also by other even more complex challenges such as the relationship between manufacturer and customer. That demands us to be more professional without losing the close and sensitive treatment to their needs which has always characterized us. A sample of this is the new collection presented in this catalogue. A summary of experiences materialized in products that have arisen as a result of the transmitted by our customers over the past 50 years.

---

.Francisco Juan Martínez.

## ¿Como empezó todo? ¿Que le hizo ponerse en marcha para fundar la empresa?

Cuando se escribe la historia de una empresa es fácil caer en la retórica de la literatura. En la reconstrucción de sus orígenes es fácil idealizar y crear el personaje, pero una empresa no es una persona: es el resultado de la tenacidad combinada con una habilidad innata empresarial. Una mezcla de intuición, de voluntad de mucho trabajo y por qué no, incluso un poco de suerte, que no hace daño. Los principios de los setenta vieron, con el desarrollo del mercado interno, consolidarse las pequeñas y medianas empresas. Muchas de ellas se limitaron al styling, muy pocas cambiaron sus técnicas de producción. Precisamente en esta escena me sentí que había una necesidad de modernizar, que había espacio para el cambio. Yo como fabricante tenía experiencia y decidí aportar los cambios que la época pedía. Fue un gesto instintivo una vez llegado el momento.

## ¿Es difícil conservar a día de hoy la misma filosofía del comienzo?

Desde el momento en que comenzó la transformación en la empresa, la filosofía del grupo comenzó a evolucionar a través de diferentes etapas. Beltá & Frajumar se mueven en un área tan delicada: la emocional como es la línea del diseño y lo hace con la misma pasión, la misma atención al detalle de siempre, añadiendo cada año nuevas propuestas, innovación de vanguardia y estilo atemporal, que lo hará la alegría del cliente final, incluso después de varios años. Mobiliario que hablan de nosotros, para el hogar, oficina o contract hotelero.

## ¿Cual es hoy su satisfacción?

*“Tres hijos, una empresa tan grande. A veces nos fijamos, mi esposa y yo en ello. ¿Quién hubiera pensado que hubiéramos hecho todas estas cosas?”.* Este es el único momento de debilidad emotiva por parte de Francisco padre en el “balance” de su vida, la de su familia y la de Beltá & Frajumar, la compañía que fundó en los años sesenta. Un momento de emoción compensado por la alegría generada de la idea de que sus hijos se hicieron cargo de la empresa como en una carrera de relevos que cada día se vuelve más y más difícil, pero al ver que son capaces y han estado dispuestos a escoger una filosofía de vida que es la interrelación entre el trabajo y la familia.

.Francisco L. Juan Ortiz.

## ¿El porque de este catalogo?

“Para demostrar la capacidad de hacer girar entorno a Beltá & Frajumar el network de la excelencia artesanal e industrial. Capacidad que ha hecho posible, desarrollar líneas de productos, fabricados aquí, complejos y originales, con gran atención al detalle, capaces de satisfacer las demandas de un público internacional, que como sabemos, es cada vez más exigente. La búsqueda de la calidad es un elemento fundamental para nosotros y es percibido por el mercado que nos da la confianza. Gracias a esto, también fuimos capaces de poner en marcha una estrategia dedicada al contract: capaces de diseñar, construir y equipar proyectos a la medida “one of a kind”. También contamos con estudios internacionales de diseño de interiores y tratamos de diferenciamos sea en el producto o sea en el servicio. Nuestra estructura y organización es la clave de lo que somos hoy“.

.Carlos L. Juan Ortiz.

## ¿Cuál es el producto o gama de productos que mejor representa a la empresa hoy en día?

Hoy puedo decir que nuestra empresa, en lugar de un producto en concreto, busca por encima de todo comunicar una marca, una forma de interpretar los ambientes, ofreciendo a los clientes un sistema para poder personalizar sus hogares. Entre todos los productos, no es más que un producto o una línea que nos representa. Nuestros diseños no siguen las tendencias, están hechos para no cansar. Los modelos deben perdurar en el tiempo, no sólo como material de resistencia al desgaste, si no por su estética; los que viven en la casa, de hecho, no tienen que cansarse pronto de aquello que tienen, deben estar convencidos de su elección, incluso después de algún tiempo.

.Jorge Juan Ortiz.

## ¿Cuales son los retos futuros? ¿Qué es y sobre todo cuál será el papel de Beltá & Frajumar en el escenario actual, durante la transformación de la relación entre el diseño, las empresas y los clientes?

Hoy Beltá & Frajumar están viviendo una gran transformación. Y no sólo, para empezar con lo obvio, el nuevo showroom de 1200 metros cuadrados, que se ha convertido en el punto de encuentro del Hospitality Design, sino también por otros retos incluso más complejos como la relación entre fabricante y cliente. Que nos demanda una mayor profesionalización sin perder el trato cercano y sensible a sus necesidades que siempre nos ha caracterizado. Una muestra de todo ello es la Nueva Colección que se presenta en este catálogo. Un resumen de experiencias materializadas en productos que han surgido a raíz de lo transmitido por nuestros clientes durante los últimos 50 años.

---

.Francisco Juan Martínez.

## Comment est-ce que tout est commencé ? Quelle est la raison pour la quelle vous avez décidé de créer sa société ?

Quand on écrive l’histoire d’une entreprise, il est facile de tomber dans la rhétorique de la littérature. Dans la reconstruction de ses origines est facile d’idéaler et créer le personnage, mais une société n’est pas un personne : c’est le résultat de la ténacité, combiné avec une capacité innée en affaires. Une mélange d’intuition, de la volonté pour travailler beaucoup et, pourquoi pas, même un peu de chance, qu’Il ne fait pas de mal. Les débuts des années 70 ont vu, avec le développement du marché intérieur, la consolidation des petites et moyennes entreprises. Beaucoup d’entre eux se sont limités à changer le styling, seulement très peu entreprises ont changé ses techniques de production. Concrètement dans cette scène, j’ai senti que nous avions

besoin d’une modernisation, qu’il y avait d’espace pour le changement. En tant que fabricant, j’avais l’expérience et j’ai décidé d’apporter des changements que la situation demandé. C’était un geste instintif quand le temps est arrivé.

## Comment de difficile est garder la même philosophie du début aujourd’hui ?

À partir du moment où la transformation de la société a commencé, la philosophie du groupe a commencé à évoluer à travers de différentes étapes. Beltá & Frajumar se déplacent dans une zone sensible : l’émotionnel comme il s’agit de la ligne de la conception et le fait avec la même passion, la même attention aux détails, en ajoutant chaque année de nouvelles propositions, d’innovation de style avant-garde et intemporel, qui fera la joie du client final, même après plusieurs années. Les meubles qui parlent de nous, pour la maison, le bureau ou le contrat de l’hôtel.

## Ce qui est votre satisfaction aujourd’hui ?

*« Trois enfants, une entreprise si grande. Parfois, ma femme et moi faisons attention en eux. Qui aurait cru que nous pourrions faire toutes ces choses ? »* C’est le seul moment de faiblesse émotionnelle par Francisco père dans le bilan de sa vie, sa famille et celle de Beltá & Frajumar, la société qu’il a fondé dans les années 1960. Un moment d’émotion compensée par la joie générée de l’idée que leurs enfants étaient en charge de la société comme dans une course de relais qui chaque jour devient plus et plus difficile, mais voyant qu’ils sont capables et ils sont disposés à choisir une philosophie de vie qui est la interaction entre le travail et la famille.l trabajo y la familia.

.Francisco L. Juan Ortiz.

## Quel est la cause de ce catalogue ?

« Pour démontrer la capacité de faire tourner autour Beltá & Frajumar le réseau de l’excellence artisanale et industrielle. Capacité qui a permis développer des gammes de produits, fabriqués ici, complexes et très originales, avec une grande attention aux détails, en mesure de répondre aux exigences d’un public international, qui comme nous le savons, est de plus en plus exigeants. La recherche de qualité est un élément clé pour nous et elle est perçue par le marché qui nous donne confiance. Grâce à cela, nous étions aussi en mesure de mettre en place une stratégie dédiée au contrat : capable de concevoir, construire et équiper des projets personnalisés “one of a kind”. Nous avons aussi des études de design d’intérieur international et nous essayons de nous différencier soit par le produit soit par le service. Notre structure et notre organisation est la clé de ce que nous sommes aujourd’hui. »

.Carlos L. Juan Ortiz.

## Qui est le produit ou la gamme de produits qui représente le mieux possible l’entreprise aujourd’hui ?

Aujourd’hui, je peux dire que notre société, en lieu d’un produit spécifique, recherche avant tout communiquer une marque, une façon d’interpréter les environnements, offrant aux clients un système pour être en mesure de personnaliser leurs maisons. Parmi tous les produits, il n’est pas plus qu’un produit ou d’une ligne qui nous représente. Nos modèles ne suivent pas les tendances, sont faites pour que le client ne se fatigue pas d’eux. Les modèles devraient durer au fil du temps, non seulement comme un matériau de résistant à l’usure, sinon pour son esthétique ; ceux qui vivent dans la maison, en fait, ne vont pas se fatiguer tôt de ce qu’ils ont, ils doivent être convaincus de son choix, même après un certain temps.

.Jorge Juan Ortiz.

## Quels sont les défis futurs ? Ce qui est et, surtout, quel sera le rôle de Beltá & Frajumar dans le scénario actuel, au cours de la transformation de la relation entre la conception, les entreprises et les clients ?

Aujourd’hui, Beltá & Frajumar subissent une grande transformation. Et pas seulement, pour commencer avec ce qui est évident, le nouveau showroom de 1200 mètres carrés, qui est devenu le point de rendez-vous pour Hospitality Design, mais aussi par d’autres défis encore plus complexes tels que la relation entre le fabricant et le client, qui nous exige un plus grand professionnalisme sans perdre le traitement étroit et sensible à leurs besoins, qui nous a caractérisé toujours. Un exemple de ceci est la Nouvelle Collection présentée dans ce catalogue. Un résumé des expériences matérialisé dans les produits qui ont surgi à la suite de la transmission par nos clients au cours des 50 dernières années.

# DESIGNERS



DARIO GAGLIARDINI



JORGE PENSI ESTUDIO



DSIGNIO



NIEVES CONTRERAS



EDUARDO CLIMENT



PABLO CANO



PAOLO MAURI



MAJO TUMINI



VICENTE GALLEGA



SERGIO MUÑOZ

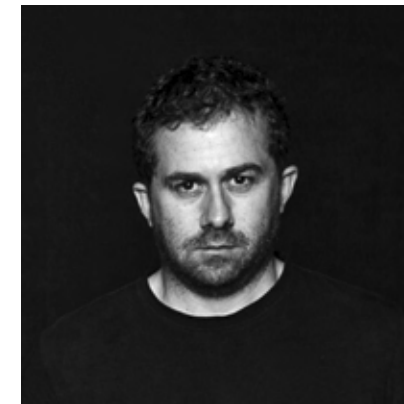

ALEJANDRO AZORÍN



ROBERT ORTEGA



JACOB PRINGIERS



LLUÍS CODINA



JAVIER HERRERO



CARLOS JUAN ORTIZ



FRANCISCO L. JUAN ORTIZ



JORGE JUAN ORTIZ

# INDEX BELTÁ

## SOFA



AXIS 14-17\_Tc 100



ERIK 10-13\_Tc 100



GUES 18-19\_Tc 101



LOFT 24-25\_Tc 101



MOKA 20-23\_Tc 102



NEWY 34-35\_Tc 102



OVVO 32-33\_Tc 103



SLIM 26-27\_Tc 103



SUIT 28-29\_Tc 104



WING 30-31\_Tc 104

## CONTRACT



EDGE 40-41\_Tc 105



LIVE 42-43\_Tc 105



LOOK 44-47\_Tc 106



LUKA 36-37\_Tc 106



TINK 48-51\_Tc 107



## DIVAN



INSIDE 52-53\_Tc 107

## ARMCHAIR



ADEX 56-57\_Tc 108



ARKO 63\_Tc 108



BLOM 54-55\_Tc 108



BOSS 78\_Tc 109



DELTA 60-61\_Tc 109



DELP 66\_Tc 109



DIBA 76\_Tc 110



ECKO 62\_Tc 110



EVEN 77\_Tc 110



GICA 81\_Tc 111



GOIA 79\_Tc 111



LUKA 59\_Tc 113



LOOK 67\_Tc 106



MARC 70-71\_Tc 111



MUSE 72-73\_Tc 112



OPOF 80\_Tc 112



PAO 72-73\_Tc 112



PLAY 74-75\_Tc 113



PUNK 64-65\_Tc 112



TEMPO 68-69\_Tc 113



TOUPIE 58\_Tc 113

## TABLE



AGOL 89\_Tc 114



BACK 90\_Tc 114



EVEN 94\_Tc 115



FRES 92\_Tc 115



ICON 82-83\_Tc 114



ISEN 91\_Tc 116



LUNA 84\_Tc 116



OPEN 87\_Tc 116



PENT 85\_Tc 117



POK 93\_Tc 117



RAIZ 88\_Tc 118



RUND 86\_Tc 118

## COMPLEMENT



LIAM 96-97\_Tc 119



SOFT 95\_Tc 119



DODU - CUSHIONS 98-99\_Tc 119

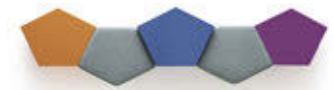

PENT 85\_Tc 117

FABRICS / TEJIDOS / TISSUS 210-212  
FINISHES / ACABADOS / FINITIONS 213

# INDEX FRAJUMAR

## SOFA



**BASIK 138-141\_Tc 196**



**COOL 142-145\_Tc 196**



**COSY 124-125\_Tc 197**



**EGOS 134-135\_Tc 197**



**EMUC 146-149\_Tc 198**



**GINA 162-165\_Tc 198**



**KIRK 152-155\_Tc 199**



**LIME 160-161\_Tc 199**



**LOBI 150-151\_Tc 199**



**MOMA 126-127\_Tc 200**



**MUSA 158-159\_Tc 200**



**MYMA 156-157\_Tc 201**



**NIMO 136-137\_Tc 201**



**PAIR 166-167\_Tc 202**



**SOUL 132-133\_Tc 202**

## RELAX



**KLAS 128-131\_Tc 203**



**EGAN 176\_Tc 203**



**MILO 177\_Tc 203**

## SOFA BED



**DARO 172-173\_Tc 204**



**CORA 168-169\_Tc 204**



**MUKA 174-175\_Tc 205**



**TRUE 170-171\_Tc 205**

## ARMCHAIR



**ALMA 185\_Tc 206**



**CITY 182\_Tc 206**



**IOVA 186\_Tc 206**



**LASE 183\_Tc 206**



**OFRE 180-181\_Tc 207**



**ONLY 178-179\_Tc 207**



**SALO 184\_Tc 207**



**TOMO 188\_Tc 207**



**VERA 187\_Tc 208**



**VINA 189\_Tc 208**

## TABLE



**ALO 190\_Tc 208**



**GIB 191\_Tc 208**



**RING 192\_Tc 209**



**SAIL 193\_Tc 209**

## COMPLEMENT



**CUBE 194\_Tc 209**



**CUSHIONS 195\_Tc 209**



# LIFE STYLE

beltá®

*Synthesis between  
innovation and  
classicism*

**ERIK**  
Design Dario Gagliardini







ERIK sofa, sofà, canapé  
DELP armchair, butaca, fauteuil

**This proposal aims to the result of a synthesis between innovation and classicism, which is characterized by the ability to create a warm environment around the sofa, thanks to its geometry.**

*Esta propuesta tiene como objetivo el resultado de una síntesis entre la innovación y el classicismo, que se caracteriza por la posibilidad de crear un acogedor espacio entorno al sofá, gracias a su geometría.*

*Cette proposition a comme but le résultat d'une synthèse entre innovation et le classicisme, qui se caractérise par la possibilité de créer un espace confortable autour du canapé, grâce à sa géométrie.*



# Powerful sign of expression

## AXIS

Design Dario Gagliardini

AXIS sofa, *sofá*, canapé

SAIL table, *mesita*, side table



**Axis seeks the essence of the objects become a powerful sign of expression. Through the refining of shapes we get an object of precise shapes in which the movement of the arm appears to explore different positions.**

*Axis busca la esencia de los objetos para convertirse en un poderoso signo de expresión. A través de la depuración de la forma se obtiene un modelo de líneas exactas en las que aparece el movimiento del brazo para explorar diferentes posiciones.*

Axis cherche l'essence des objets pour se transformer en un signe puissant d'expression. À travers de l'épuration des formes on obtient un modèle avec des lignes exactes dans lesquelles le mouvement du bras apparaît pour explorer différentes positions.



# *Timeless character*

**GUES**  
Design Arbel



*Style to dress  
heterogeneous  
spaces*

**MOKA**

MOKA sofa, *sofá*, canapé  
BACK table, *mesita*, side table



MOKA



OP. 1



OP. 2



# A bohemian sofa

## LOFT

Design Arbel

**LOFT sofa**, sofá, canapé.

**ECKO armchair**, butaca, fauteuil

**A different sofa, complex in terms of its concept but with an impeccable result. A classic soul translated into a contemporary language through the use of line and shape.**

*Un sofá distinto, complejo en cuanto a su concepto de partida pero con un resultado impecable. Un alma clásica traducida a un lenguaje contemporáneo a través del recurso de la línea y la forma.*

Un canapé différent et complexe sur le plan de son concept de jeu, mais avec un résultat impeccable. Une âme classique traduit dans un langage contemporain grâce à l'utilisation de la ligne et la forme.



# A light and elegant sofa

## SLIM

Design Arbel

SLIM sofa, *sofá*, canapé

RUND table, *mesita*, side table

OPOF pouff





# *A wide variety of options*

## **SUIT**

Design Robert Ortega

**SUIT sofa, sofá, canapé**

**LUNA table, mesa**





## WING

Design Dario Gagliardini

**WING sofa**, *sofá*, *canapé*

**EVEN table**, *mesa*

**FRES side table**, *mesita*, *table auxiliaire*

**A system of upholstery that allows great flexibility departing from the bench as the basic element, and adding elements, such as the arms and back, to create configurations that meet bespoke requirements or by choosing the suggested compositions.**

*Un sistema de tapizados que permite una gran flexibilidad a partir de la bancada, como elemento básico, y añadiendo elementos, tales como los brazos y los respaldo, para formar configuraciones que cumplen con los requisitos de poder personalizar o eligiendo en las composiciones sugeridas.*

Un système de tapisés qui permet une grande flexibilité à partir de l'assise, comme l'élément de base et en ajoutant les éléments, tels que les bras et retour, pour faire configurations qui satisfont les exigences pour pouvoir personnaliser ou choisir entre les compositions proposées.



# Organic and compact shapes

## OVVO

OVVO sofa, *sofá*, canapé  
LUNA table, *mesa*



*To suit  
nowadays  
needs*

**NEWY**  
Design Sergio Muñoz



# *Iconic piece*

**LUKA**  
Design Jorge Pensi



REF. 7261P



REF. 7251P

Luka is a family of armchairs, sofas and chaise longue to settle contract spaces, but also to furnish the home. The idea is to create an iconic piece, and it is achieved because of its strong personality.

*Luka es una familia de butacas, sofás y chaiselongue para ambientar espacios contract, pero también amueblar el hogar. La idea es la creación de una pieza icónica, y lo consigue por su fuerte personalidad.*

Luka est une famille de fauteuils, canapés et chaise longue à s'installer dans des espaces de contrat, mais aussi pour meubler la maison. L'idée est la création d'une oeuvre emblématique et il s'obtient à travers de sa forte personnalité.



REF. 7245P



REF. 7255P



REF. 7265P



REF. 7253P

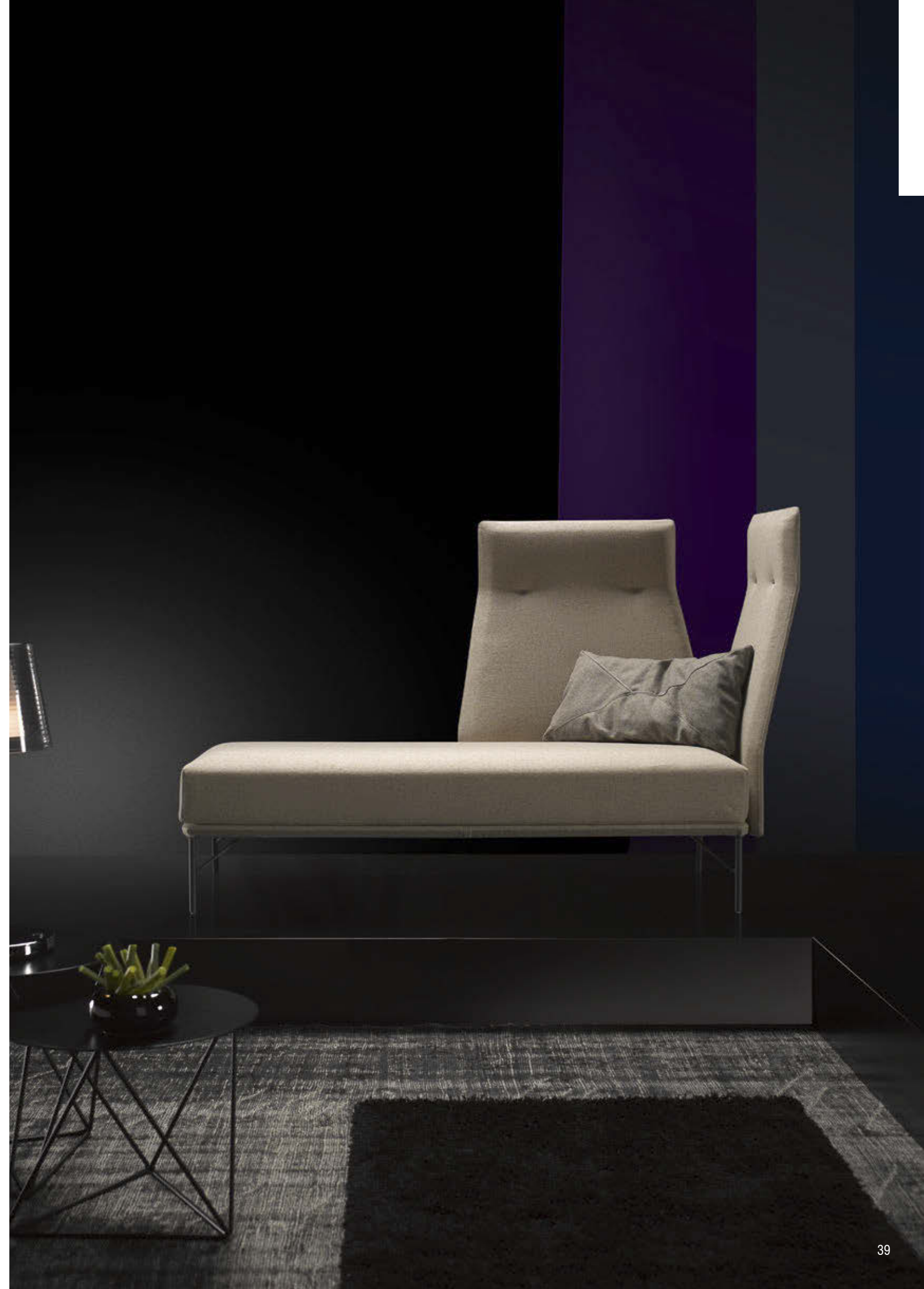



# Ability to create complex shapes

## EDGE

Design Jacob Pringiers

**Edge is a game proposal, where the geometry and complementarity creates a simple object in appearance but that hides a detailed shape research. The main feature that offers Edge is its ability to create complex shapes from a single module. Designed especially for Contract spaces is ideal for composing images and sensations.**

*Edge es una propuesta de juego, una propuesta en donde la geometría y la complementariedad crean un objeto en apariencia sencillo pero que esconde un estudio detallado de la forma. El rasgo principal que ofrece Edge es su capacidad de crear formas complejas a partir de un único módulo. Pensado especialmente para espacios contract es idóneo para componer imágenes y sensaciones.*

Edge nous offre une liberté de jeu, un jeu où la géométrie et la complémentarité ont créé un objet d'une apparence simple mais qui cache une étude très détaillée de la forme. Le trait principal qu'Edge offre est sa capacité de créer des formes complexes à partir d'un module unique. Pensé spécialement pour des espaces contract, il est idéal pour composer des images et des sensations.



# *Dynamic shapes*

**LIVE**  
Design Dsignio





*Powerful  
expression sign*

**LOOK**

Design Vicente Gallego



## LOOK

**Look model combines to perfection comfort, sobriety and pure lines as well as wood and steel combination in order to integrate it in the environment we desire to achieve.**

*El modelo Look conjuga a la perfección la comodidad, la sobriedad y la pureza de líneas, así como la combinación con materiales como el acero o la madera a fin de facilitar la perfecta integración en el ambiente que se desea conseguir.*

Le modèle Look allie à la perfection le confort, la simplicité et la pureté des lignes, ainsi que la combinaison avec des matériaux comme l'acier ou le bois afin de faciliter l'intégration parfait dans l'environnement que vous souhaitez obtenir.



# *Simple and sophisticated design*

**TINK**  
Design Dsignio

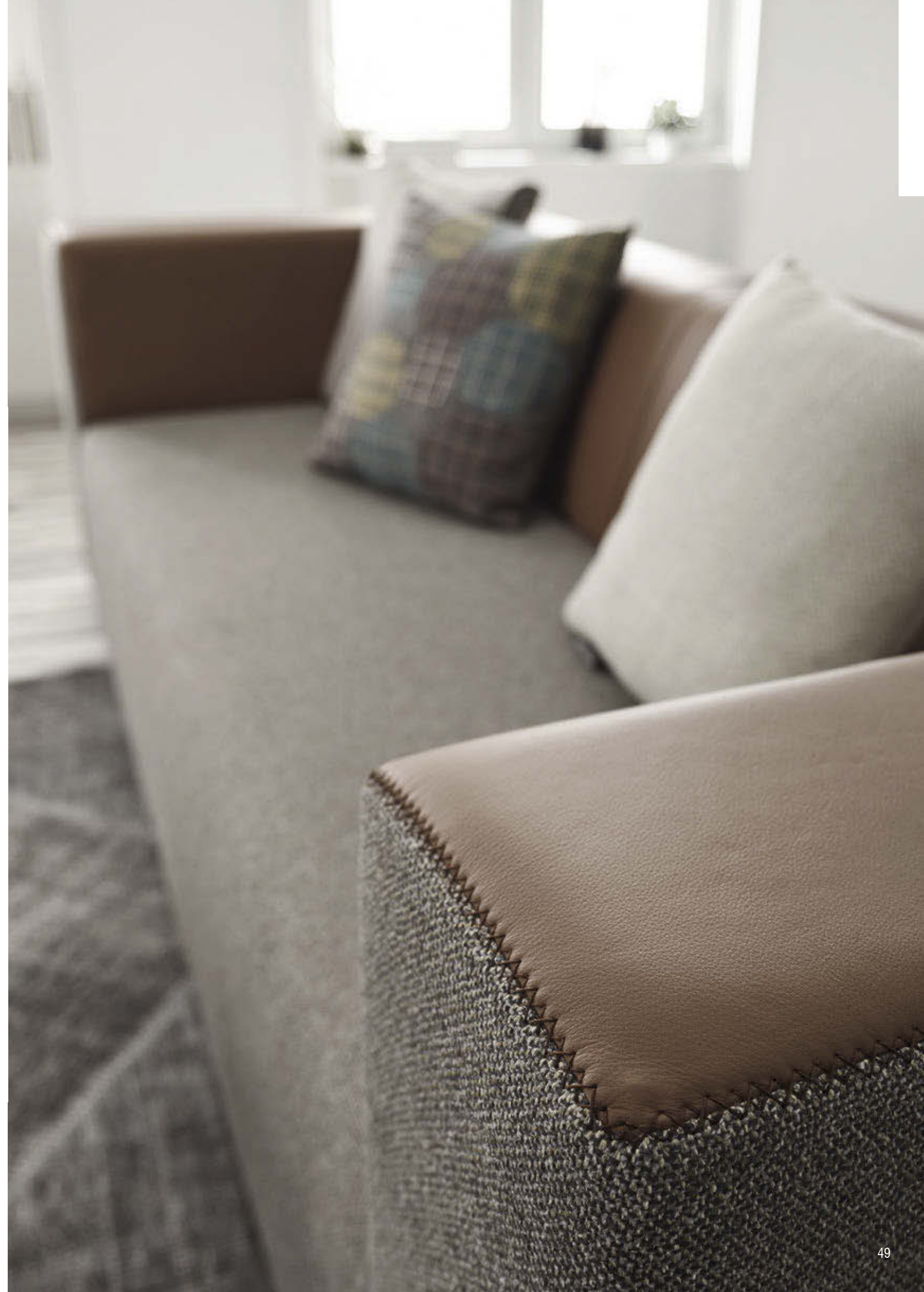

TINK sofa, *sofá*, canapé  
BOSS armchair, *butaca*, fauteuil  
SAIL table, *mesa*  
MUSE chair, *silla*, chaise  
POET desk, *escritorio*, bureau  
PENT ottoman, *pouff*





# *Dynamic and avant-garde shapes*

## **INSIDE**

Design Rafa y Miguel Ángel García

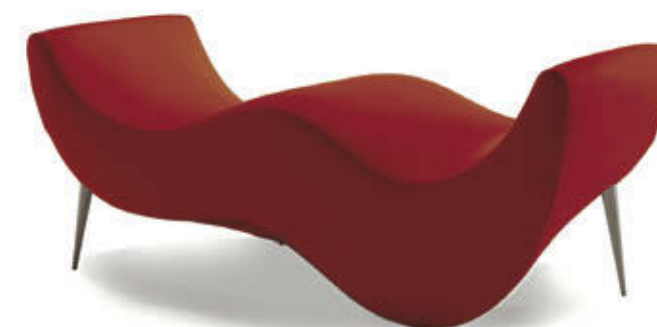

# *Timeless character*

## **BLOM**

Design Alejandro Azorín

**BLOM armchair**, *butaca*, fauteuil  
**OPEN side table**, *mesita*, table



# Inspired by some classic early 20th century pieces

## ADEX

Design Alejandro Azorín

**Design inspired by some classic early 20th century pieces. This armchair combines the feeling of great comfort, with sobriety and rigidity of a minimalist structure.**

*De diseño inspirado en algunas de las piezas clásicas de principios de S.XX, esta butaca conjuga la sensación de un gran confort, con la sobriedad y rigidez de una estructura minimalista.*

Fauteuil de design inspiré par certains classiques de début XXème siècle, ce modèle combine la sensation de grand confort, avec une sobriété et la rigidité d'une structure minimaliste.



REF. 222BU



REF. 222BA



# TOUPIE

Design Nieves Contreras

1st Prize International Furniture Industrial Design of Cetem contest, 2012.

1º Premio Concurso Internacional del Mueble de Cetem, 2012.

1er Prix International du Meuble design industriel de Cetem, 2012.



# LUKA

Design Jorge Pensi





# Organic inspired

## DELTA

Design Javier Herrero

DELTA armchair, *butaca*, fauteuil

FRES side table, *mesita*, table auxiliaire



# *Sophisticated Style*

**ECKO**  
Design Arbel



**ARKO**  
Design Dario Gagliardini



# *A new typology*

## **PUNK**

Design Robert Ortega



# *Creativity among all*

## **DELP**

Design Dario Gagliardini



## **LOOK**

Design Vicente Gallega



*Solidity, functionality  
and lightness*



**TEMPO**  
Design Vicente Gallega



REF. 2272B



REF. 227BU



REF. 227SI



*Synonymous  
with elegance*

**MARC**  
Design Jorge Pensi





## *Timeless and fun*

**PAO**  
Design Lluís Codina

**MUSE**  
Design Arbel





# Sets never seen

## PLAY Design Jorge Pensi

Finalist Delta Awards ADI FAD, 2011.  
Finalista Premios Delta ADI FAD, 2011.  
Finalist Prix Delta ADI FAD, 2011





# *Sinuuous shapes*

## **DIBA**

Design Dario Gagliardini



## **EVEN**

Design Robert Ortega



**BOSS**  
Design Pablo Cano



**GOIA**  
Design Pablo Cano



## OPOF

Design Dario Gagliardini



## GICA

Design Eduardo Climent

**2nd Prize International Furniture Industrial Design of Cetem contest, 2005.**

*2º Premio Concurso Internacional del Mueble de Cetem, 2005.*

*2ème Prix International du Meuble design industriel de Cetem, 2005.*

**Gica, rocking chair has simple and elegant shapes. It is an ergonomic and functional piece, with curved lines, of great simplicity and attractive design.**

*Gica, mecedora de formas sencillas y elegantes. Se trata de una pieza ergonómica y funcional, con un diseño de líneas curvas, de gran simplicidad y atractivo.*

*Berceuse dont les formes sont simples et élégantes. Il s'agit d'une pièce ergonomique et fonctionnelle, son design avec des lignes courbes, avec une grande simplicité et attractif.*



# *Craftsmanship and design*

**ICON**  
Design Arbel



**LUNA**  
Design Paolo Mauri



**PENT**  
Design Dsignio

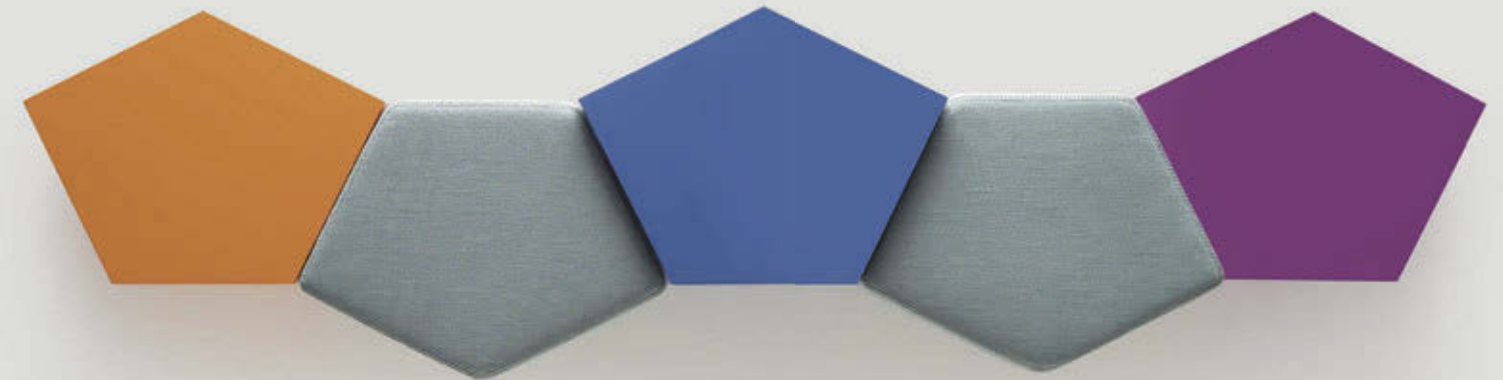

*Visual delicacy*

**RUND**  
Design Dsignio



**OPEN**  
Design Arbel



**RAÍZ**  
Design Lluís Codina



**AGOL**  
Design Gagliardini



**BACK**  
Design Robert Ortega



**ISEN**  
Design Arbel





*Extremely  
useful*

**FRES**  
Design Arbel



**POK**  
Design Arbel



**EVEN**  
Design Arbel



**SOFT**  
Design Arbel



**LIAM**  
Design Arbel



# CUSHIONS and DECORATION





REF.

**9635P**



**9634P**

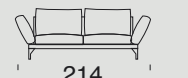

**9633P**



**9632P**



**9631P**



**963M5**

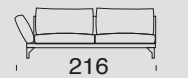

**963M4**

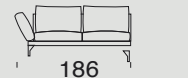

**963M3**



**963M2**



**963M1**



**9635S**

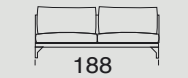

**9634S**

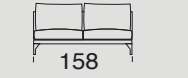

**9633S**



**9632S**



**9631S**

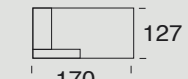

**963CH**



**963PF**



**963RI**

**OPTIONS / OPCIONES / OPTIONS**

■ LEGS / PATAS / PIEDS

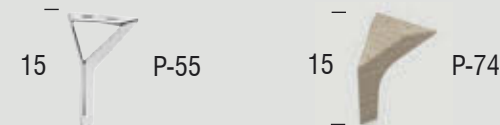

■ MECHANISM / MECANISMO / MÉCANISME

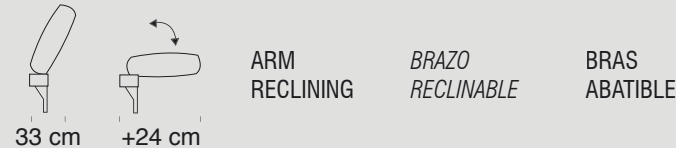

REF.

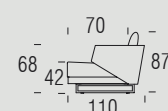

**9955P**

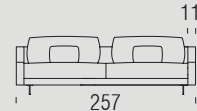

**9954P**

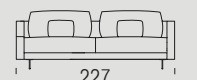

**9953P**

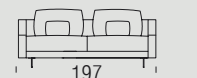

**995M5**

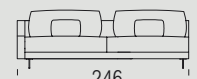

**995M4**



**995M3**

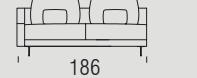

**995CH**

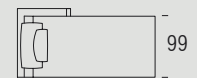

**995RI**

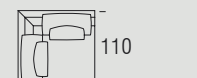

**995TR**



**OPTIONS / OPCIONES / OPTIONS**

■ LEGS / PATAS / PIEDS

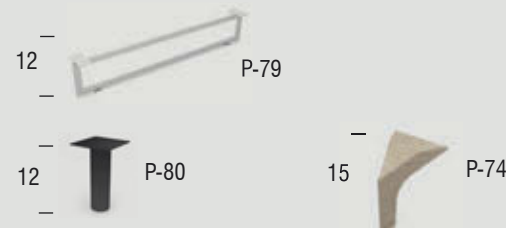

■ FINISHES / ACABADOS / FINITIONS

P-74	WENGUE		
P-74	CHERRY	CEREZO	MERISIER
P-74	ASH	FRESNO	FRÊNE
P-74	WALNUT	NOGAL	NOYER
P-74	OAK	ROBLE	CHÊNE
P-79	STAINLESS STEEL	ACERO INOX	ACIER INOX
P-80	BLACK	NEGRO	NOYER



REF.

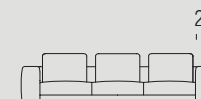

**9965P**



**9964P**

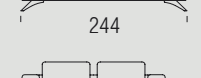

**9963P**

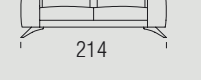

**9962P**



**996M5**



**996M4**

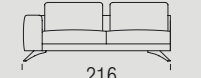

**996M3**

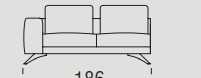

**996M2**

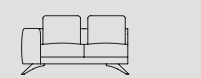

**996M1**



**996TC**



**996CH**



**996RI**



**OPTIONS / OPCIONES / OPTIONS**

■ LEGS / PATAS / PIEDS



■ STITCHING / COSTURA / COUTURE

.Definir el color del hilo de la costura decorativa.

■ FINISHES / ACABADOS / FINITIONS

P-92	WENGUE		
P-92	CHERRY	CEREZO	MERISIER
P-92	ASH	FRESNO	FRÊNE
P-92	WALNUT	NOGAL	NOYER
P-92	OAK	ROBLE	CHÊNE
P-62	ALUMINIUM	ALUMINIO	ALUMINIUM

■ REMOVABLE / DESENFUNDABLE DÉHOUSSABLE



REF.

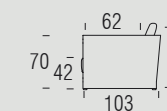

**2065P**

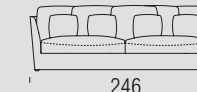

**2064P**

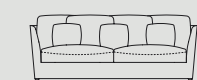

**2063P**

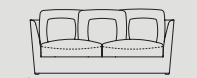

**2061P**



**206M5**

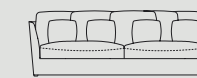

**206M4**

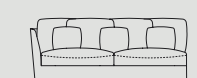

**206M3**



**206M1**



**206R1**





REF.

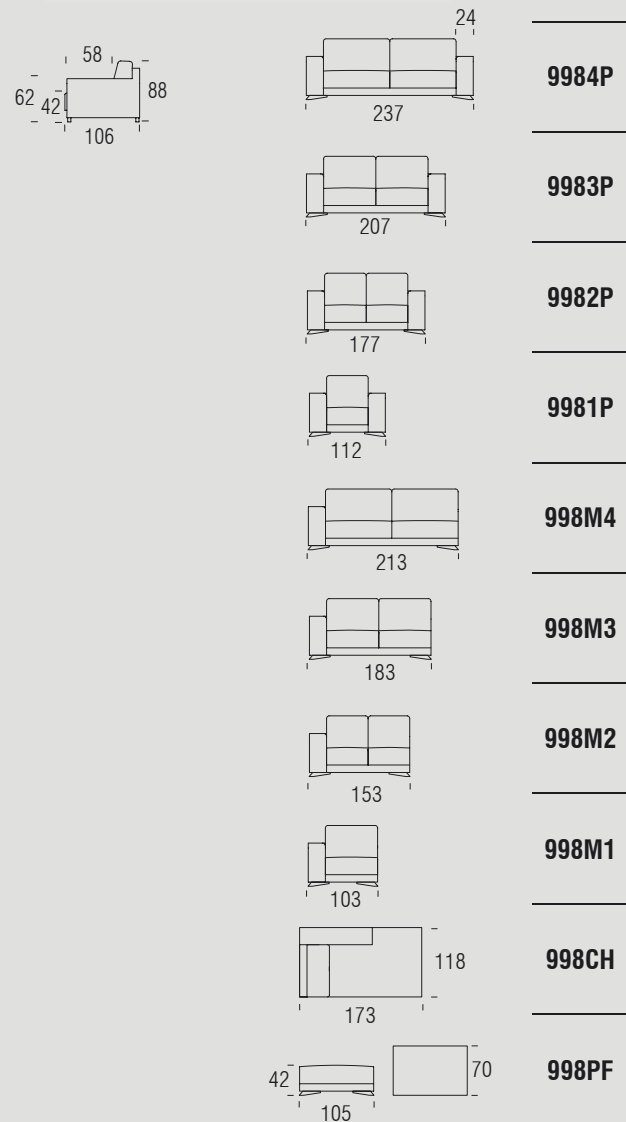

OPTIONS / OPCIONES / OPTIONS

■ LEGS / PATAS / PIEDS

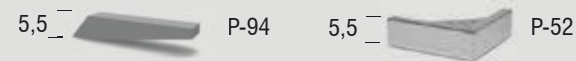

■ STITCHING / COSTURA / COUTURE

.To choose between cross stitching (OP.1) or piping (OP.2) and indicate the colour.  
 .Elegir entre costura entrelazada (OP.1) o vivo redondo (OP.2) y definir su color.  
 .Choisir entre couture entrelacée (OP.1) ou passepoil rond (OP.2) et définir sa couleur.

■ FINISHES / ACABADOS / FINITIONS

P-94	WENGUE		
P-94	CHERRY	CEREZO	MERISIER
P-94	OAK	ROBLE	CHÊNE
P-94	WALNUT	NOGAL	NOYER
P-52	CHROMED	CROMADO	CHROMÉ

■ REMOVABLE / DESENFUNDABLE / DÉHOUSSABLE



REF.

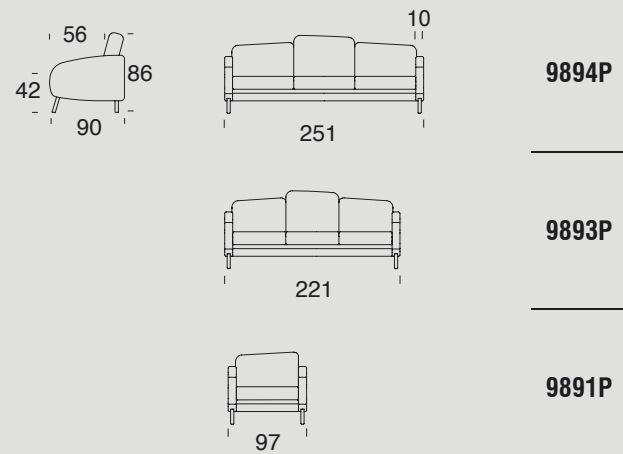

OPTIONS / OPCIONES / OPTIONS

■ LEGS / PATAS / PIEDS



■ FINISHES / ACABADOS / FINITIONS

P-78	WENGUE		
P-78	CHERRY	CEREZO	MERISIER
P-78	OAK	ROBLE	CHÊNE
P-78	WALNUT	NOGAL	NOYER



REF.

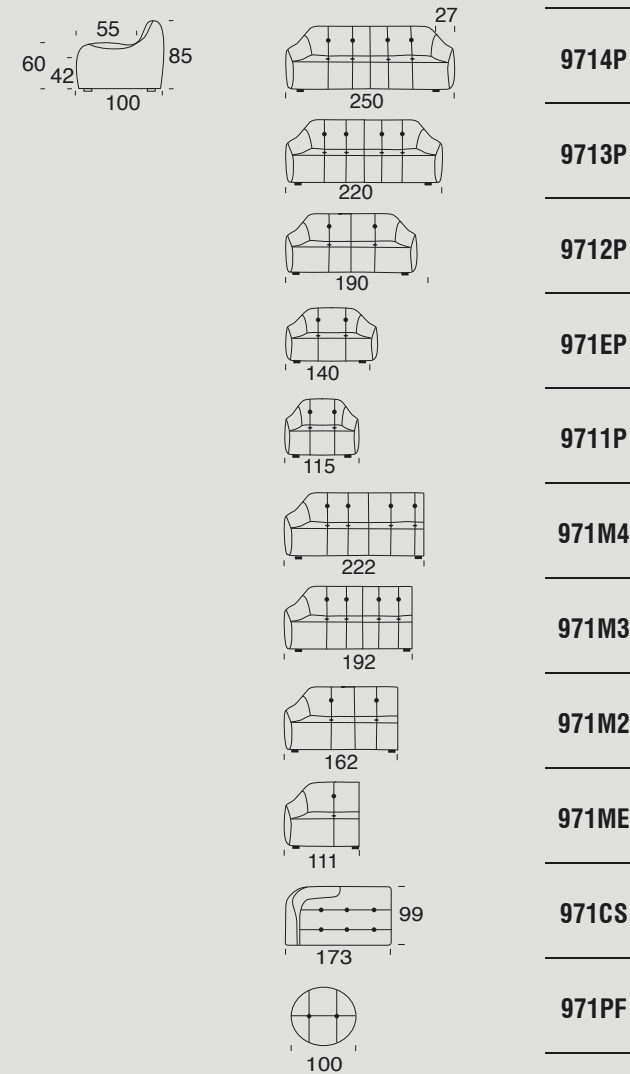

OPTIONS / OPCIONES / OPTIONS

■ LEGS / PATAS / PIEDS



REF.

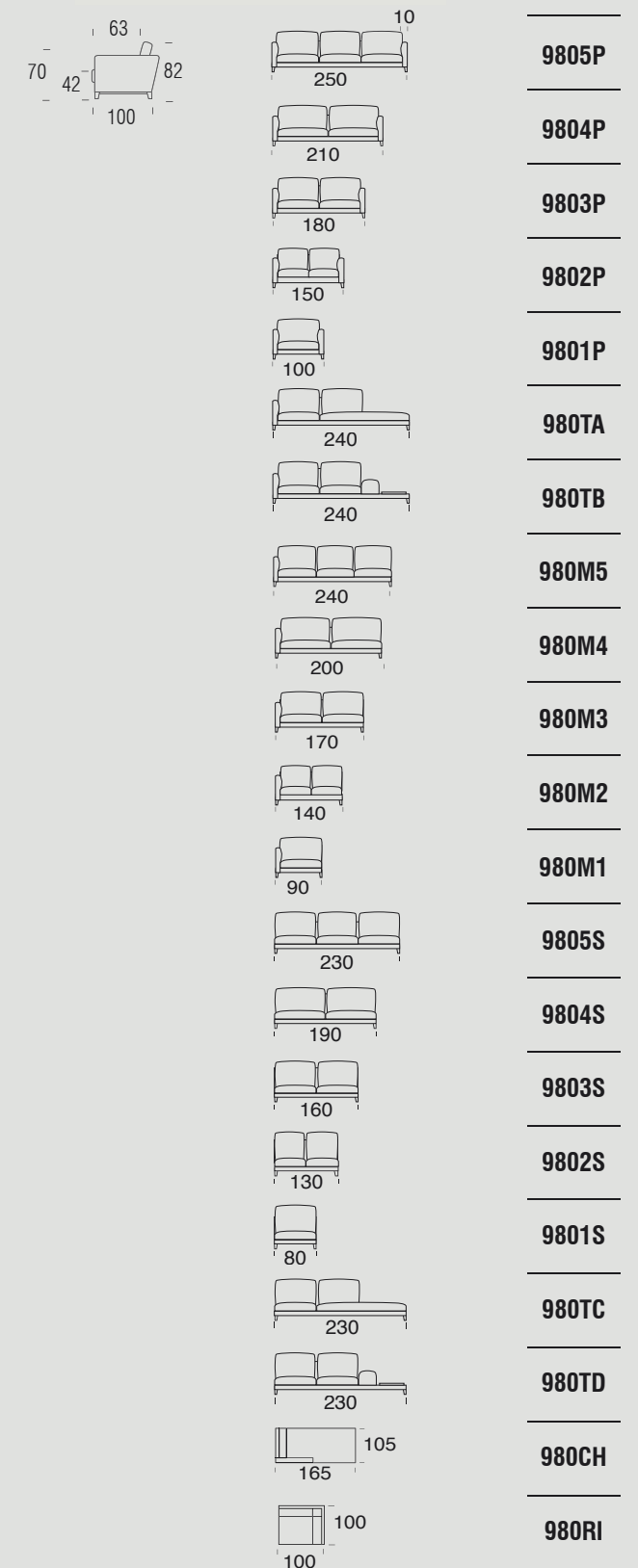

OPTIONS / OPCIONES / OPTIONS

■ LEGS / PATAS / PIEDS

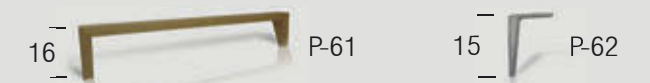

■ REMOVABLE / DESENFUNDABLE / DÉHOUSSABLE



REF.

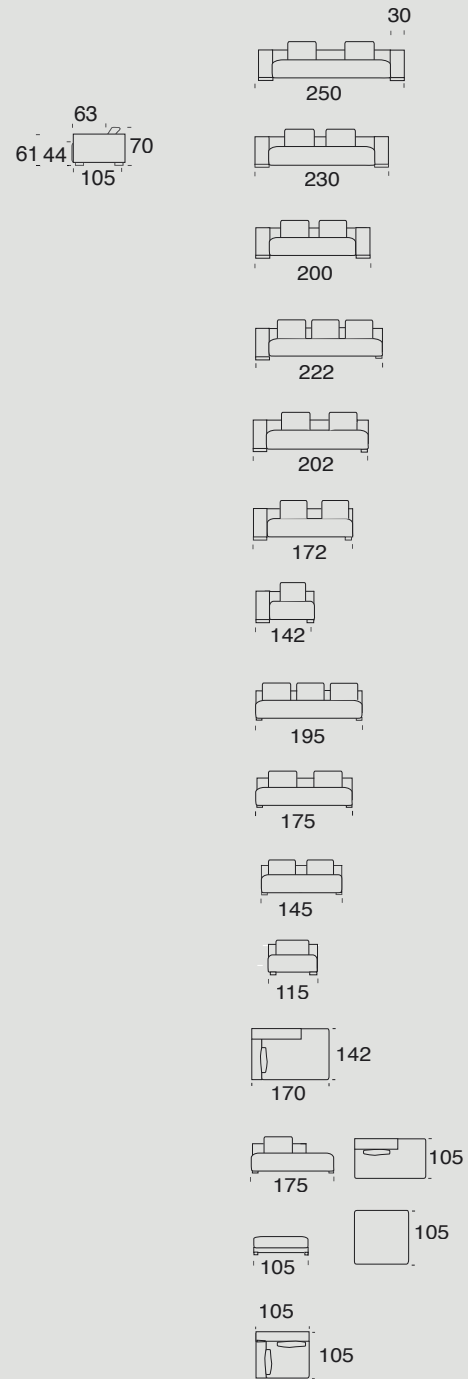

9814P

9813P

9812P

981M4

981M3

981M2

981M1

9814S

9813S

9812S

9811S

981CS

981TA

981PR

981RI

OPTIONS / OPCIONES / OPTIONS

■ LEGS / PATAS / PIEDS



■ FINISHES / ACABADOS / FINITIONS

P-25	CHERRY	CEREZO	MERISIER
P-25	OAK	ROBLE	CHÊNE
P-25	CHROMED	CROMADO	CHROMÉ

■ REMOVABLE / DESENFUNDABLE / DÉHOUSSABLE



REF.

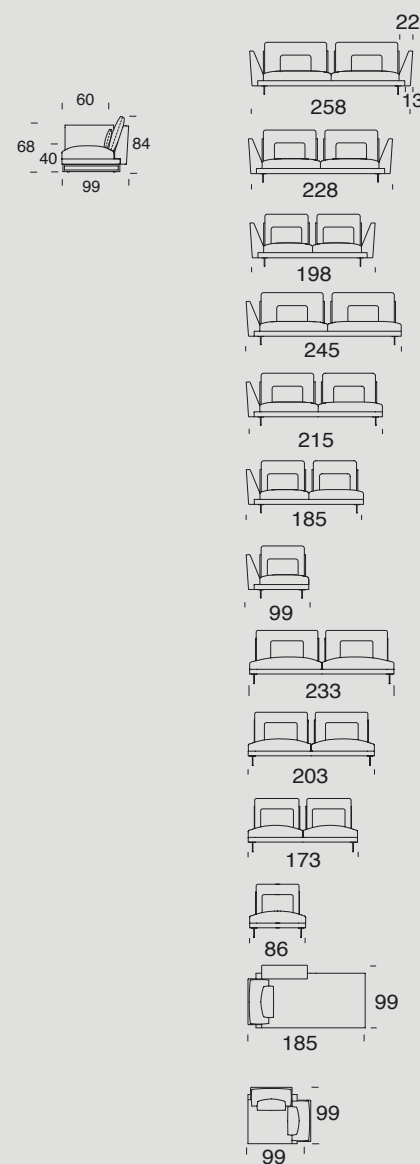

9885P

9884P

9883P

988M5

988M4

988M3

988M1

9885S

9884S

9883S

9881S

988CH

988RI

OPTIONS / OPCIONES / OPTIONS

■ LEGS / PATAS / PIEDS

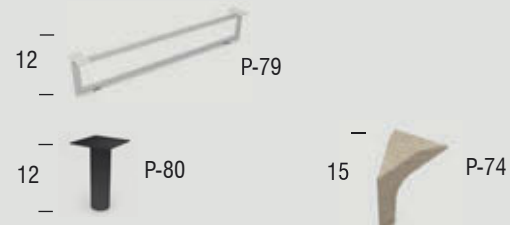

■ FINISHES / ACABADOS / FINITIONS

P-74	WENGUE		
P-74	CHERRY	CEREZO	MERISIER
P-74	ASH	FRESNO	FRÊNE
P-74	WALNUT	NOGAL	NOYER
P-74	OAK	ROBLE	CHÊNE
P-79	STAINLESS STEEL	ACERO INOX	ACIER INOX
P-80	BLACK	NEGRO	NOYER

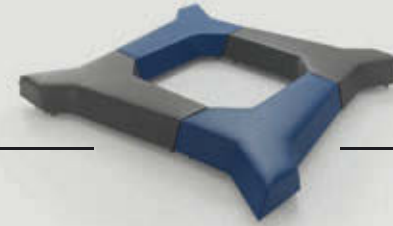

REF.

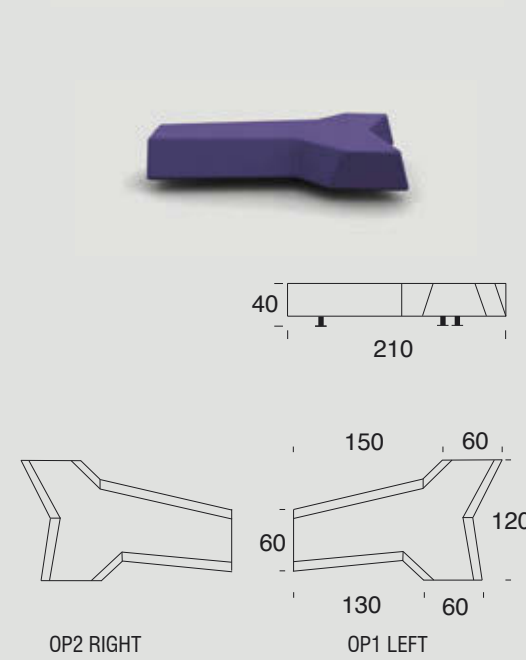

975B1

975B2

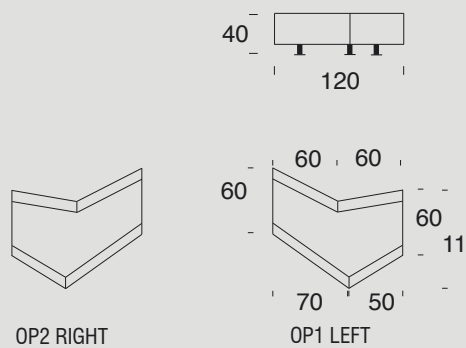

■ EXAMPLES OF COMPOSITIONS / EJEMPLO DE COMPOSICIONES

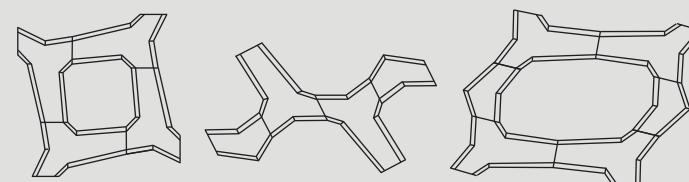

OP1



OP2

REF.

LIVE M2

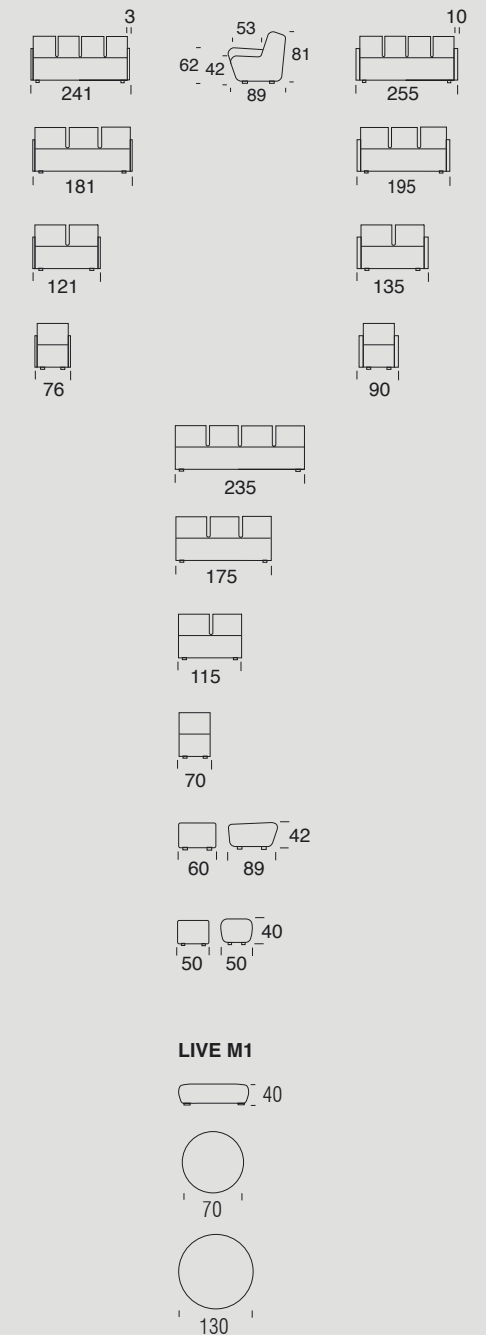

OPTIONS / OPCIONES / OPTIONS

■ LEGS / PATAS / PIEDS



■ ARMS / BRAZOS / ACCOUDOIRS





REF.

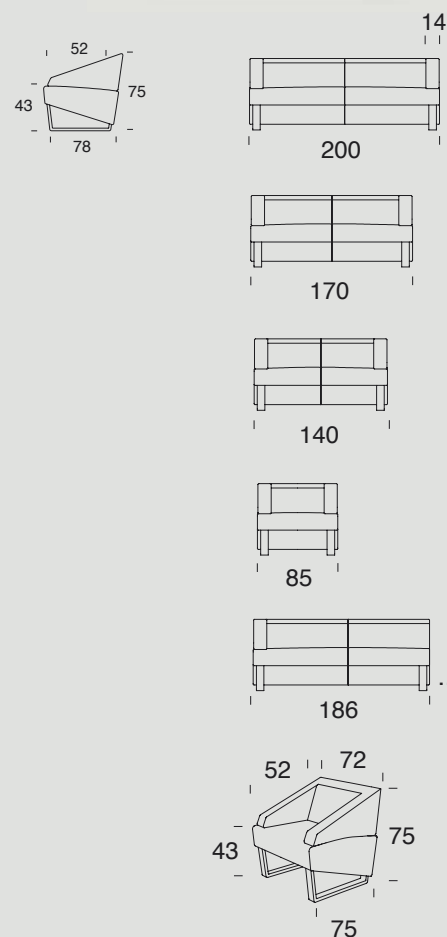

9904P

9903P

9902P

9901P

990M14

990BU

OPTIONS / OPCIONES / OPTIONS

■ LEGS / PATAS / PIEDS

STEEL / ACERO / ACIER

WOOD / MADERA / BOIS



P-76  
SOFA



P-77  
SOFA

■ FINISHES / ACABADOS / FINITIONS

P76	STAINLESS STEEL	ACERO INOX	ACIER INOX
P-77	WENGUE		
P-77	CHERRY	CEREZO	MERISIER
P-77	OAK	ROBLE	CHÊNE
P-77	WALNUT	NOGAL	NOYER



REF.

REF.

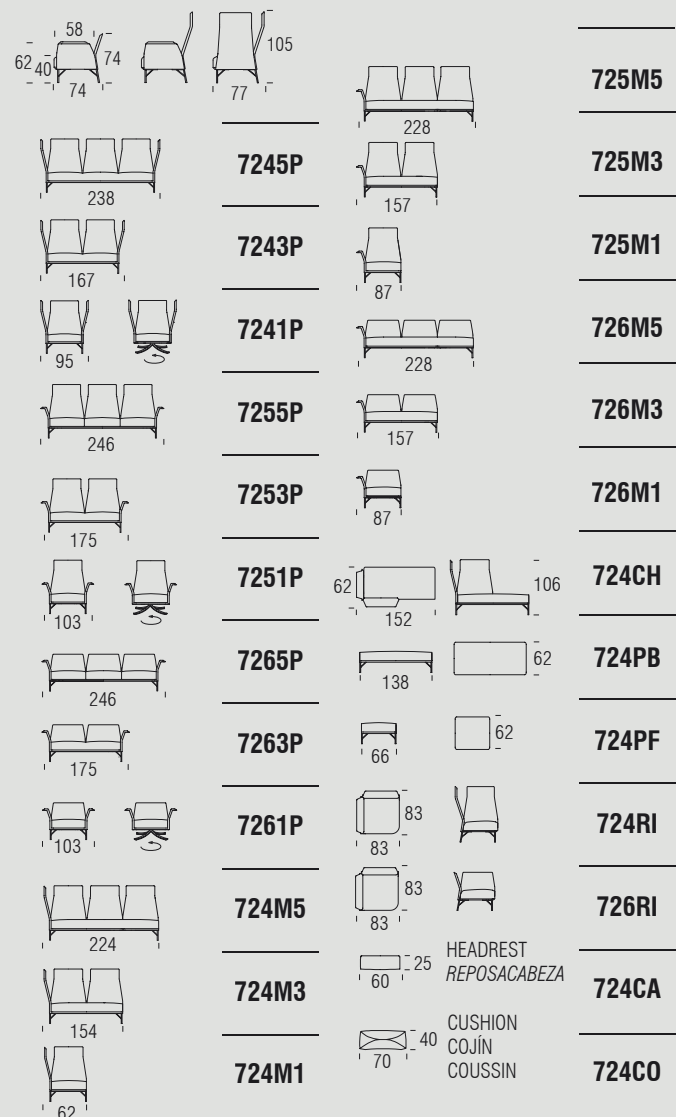

OPTIONS / OPCIONES / OPTIONS

■ LEGS / PATAS / PIEDS



■ FINISHES / ACABADOS / FINITIONS

P98	GRAPHITE	GRAFITO	GRAPHITE
P-100	STONE	PIEDRA	PIERRE

■ COMPOSITIONS / COMPOSICIONES / COMPOSITIONS

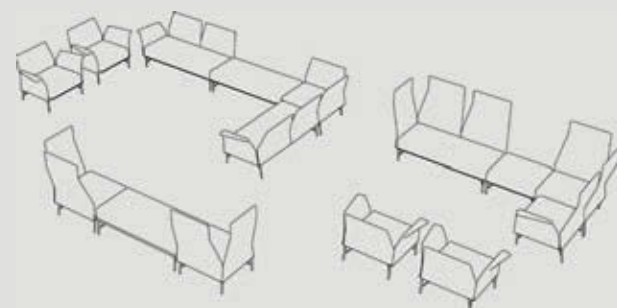

REF.

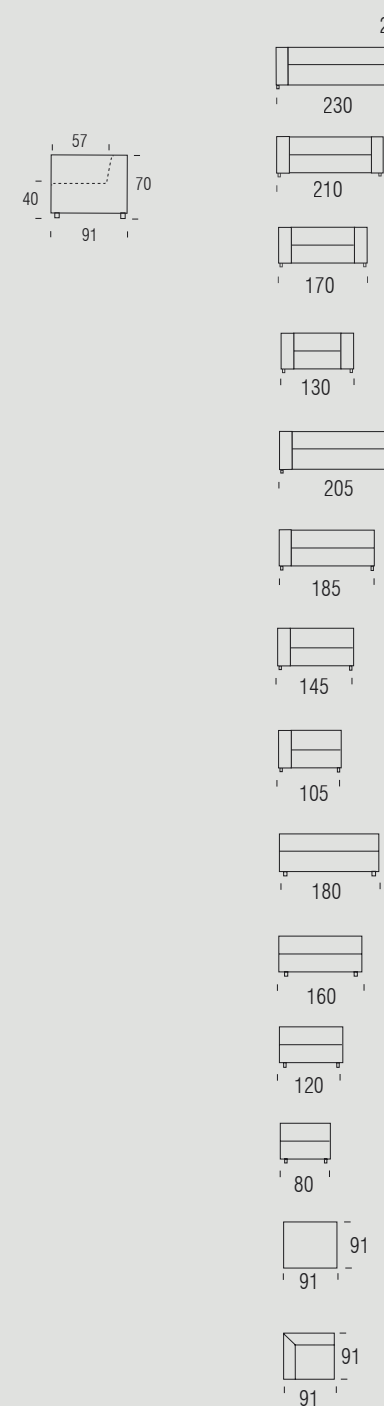

OPTIONS / OPCIONES / OPTIONS

■ LEGS / PATAS / PIEDS



■ FINISHES / ACABADOS / FINITIONS

P-25	P42	WENGUE		
P-25	CHERRY	CEREZO	MERISIER	
P-25	OAK	ROBLE	CHÊNE	
P-10	CHROMED	CROMADO	CHROMÉ	

■ STITCHING / COSTURA / COUTURE

.Indicate the colour of the decorative stitching thread.  
.Definir el color del hilo de la costura decorativa.  
.Définir la couleur du fil de la couture décorative.



REF.

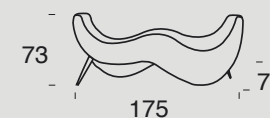

1251P

. IMPORTANT: To choose fabric, consult us.  
. IMPORTANTE: Para elegir tejido, consulte con fábrica.  
. IMPORTANT: Pour choisir tissu, consulter avec l'usine.

OPTIONS / OPCIONES / OPTIONS

■ FINISHES LEGS / ACABADOS PATAS / FINITIONS PIEDS

HANDLE LEG OPTION OPCIÓN PATA MADERA OPTION PIED BOIS	WENGUE		
	CHERRY	CEREZO	MERISIER
	OAK	ROBLE	CHÊNE
	WALNUT	NOGAL	NOYER

AISI 304 AISI 304 STEEL ACERO AISI 304 ACIER AISI 304





Ref. 222BU      Ref. 222BA      **REF.**

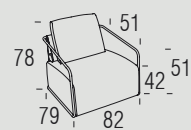

**222BU**



**222BA**

**OPTIONS / OPCIONES / OPTIONS**

■ FINISHES / ACABADOS / FINITIONS

GRAPHITE	GRAFITO	GRAPHITE
STONE	PIEDRA	PIERRE
STAINLESS STEEL	ACERO INOX	ACIER INOX
COPPER	COBRE	CUIVRE

■ STITCHING / COSTURA / COUTURE

.Indicate the colour of the decorative piping.  
.Indicar el color del vivo decorativo.  
.Définir la couleur du passepoil décorative.



**REF.**

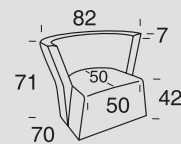

**940BU**



**940BG**

SWIVEL / GIRATORIO / PIVOTANT

**OPTIONS / OPCIONES / OPTIONS**

■ LEGS / PATAS / PIEDS



4  P-42  
HIDDEN / OCULTA

BASEBOARD / ZÓCALO / SOCLE

■ FINISHES / ACABADOS / FINITIONS

BASEBOARD	STAINLESS STEEL	ACERO INOX	ACIER INOX
P-42	WENGUE		



**REF.**

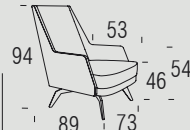

**223BT**



**223BM**



**223BU**

SWIVEL / GIRATORIO / PIVOTANT

FIX / FIJO / FIXE

**OPTIONS / OPCIONES / OPTIONS**

■ FINISHES / ACABADOS / FINITIONS

Ref.223BT	BLACK(METAL)	NEGRO(METAL)	NOIR(MÉTAL)
Ref.223BT	CORTEN STEEL	ACERO CORTEN	ACIER CORTEN
Ref.223BM/Ref.223BU	WENGUE		
Ref.223BM/Ref.223BU	WALNUT	NOGAL	NOYER
Ref.223BM/Ref.223BU	OAK	ROBLE	CHÊNE
Ref.223BM/Ref.223BU	CHERRY	CEREZO	MERISIER

■ STITCHING / COSTURA / COUTURE

.Indicate the colour of the decorative piping.  
.Indicar el color del vivo decorativo.  
.Définir la couleur du passepoil décorative.



REF. 976BU



REF. 976BB

**REF.**

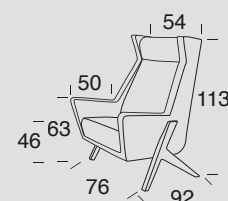

**976BU**

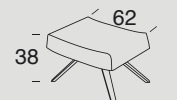

**976RU**



**976BB**

**OPTIONS / OPCIONES / OPTIONS**

■ FINISHES / ACABADOS / FINITIONS

WENGUE		
CHERRY	CEREZO	MERISIER
OAK	ROBLE	CHÊNE
WALNUT	NOGAL	NOYER



**REF.**

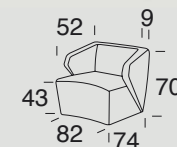

**960BU**

FIX / FIJO / FIXE



**960BG**

SWIVEL / GIRATORIO / PIVOTANT

**OPTIONS / OPCIONES / OPTIONS**

■ LEGS OP.1 / PATAS OP.1 / PIEDS OP.1

4  P-42  
HIDDEN / OCULTA

■ FINISHES / ACABADOS / FINITIONS

P-42 WENGUE



**REF.**

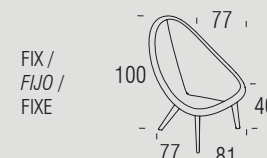

**224BU**

SWIVEL / GIRATORIO / PIVOTANT



**224BA**

**OPTIONS / OPCIONES / OPTIONS**

■ BASEBOARD / BASE / SOCLE



Ref. 224BU



Ref. 224BA

■ FINISHES / ACABADOS / FINITIONS

WENGUE		
CHERRY	CEREZO	MERISIER
ASH	FRESNO	FRÊNE
WALNUT	NOGAL	NOYER
OAK	ROBLE	CHÊNE



REF. 948BA REF. 948BB REF.

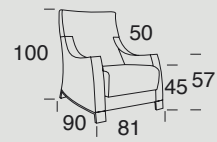

948BA

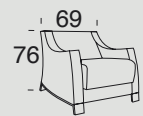

948BB



948PF

OPTIONS / OPCIONES / OPTIONS

■ LEGS / PATAS / PIEDS

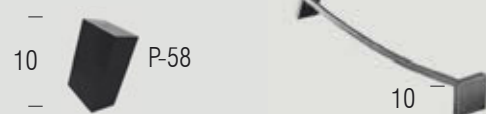

BASEBOARD / ZÓCALO / SOCLE

■ FINISHES / ACABADOS / FINITIONS

P-58	WENGUE		
P-58	CHERRY	CEREZO	MERISIER
P-58	OAK	ROBLE	CHÊNE
BASEBOARD	STAINLESS STEEL	ACERO INOX	ACIER INOX



REF.

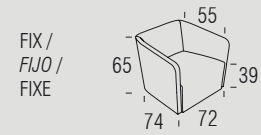

225BU



225BG

OPTIONS / OPCIONES / OPTIONS

■ LEGS / PATAS / PIEDS



HIDDEN / OCULTA

■ FINISHES / ACABADOS / FINITIONS

P-42 WENGUE

■ STITCHING / COSTURA / COUTURE

.Definir el color del hilo de la costura decorativa.



REF.

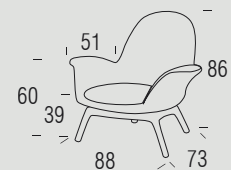

985BU

OPTIONS / OPCIONES / OPTIONS

■ BASEBOARD / BASE / SOCLE



■ FINISHES / ACABADOS / FINITIONS

WENGUE			
CHERRY	CEREZO	MERISIER	
ASH	FRESNO	FRÊNE	
WALNUT	NOGAL	NOYER	
OAK	ROBLE	CHÊNE	



REF.

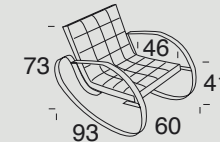

9091P

OPTIONS / OPCIONES / OPTIONS

■ FINISHES / ACABADOS / FINITIONS

WENGUE		
CHERRY	CEREZO	MERISIER
OAK	ROBLE	CHÊNE
MATT BLACK	NEGRO MATE	BLANC MAT
MATT WHITE	BLANCO MATE	NOIR MAT
LEATHER	PIEL	CUIR



REF.

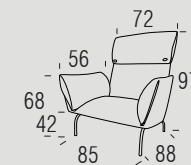

984BU

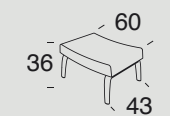

984RP

OPTIONS / OPCIONES / OPTIONS

■ BASEBOARD / BASE / SOCLE



STEEL / ACERO / ACIER

WOOD / MADERA / BOIS

■ FINISHES / ACABADOS / FINITIONS

P-67	WENGUE		
P-67	CHERRY	CEREZO	MERISIER
P-67	ASH	FRESNO	FRÊNE
P-67	WALNUT	NOGAL	NOIR
P-67	OAK	ROBLE	CHÊNE
P-66	STAINLESS STEEL	ACERO INOX	ACIER INOX



OP.1 OP.2 REF.

(STEEL)

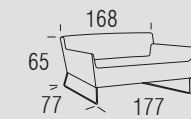

9613B

(WOOD)



9612B

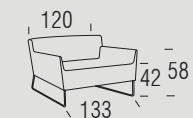

961BU

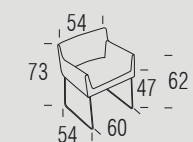

961SI

OPTIONS / OPCIONES / OPTIONS

■ LEGS / PATAS / PIEDS



OP.1 STEEL / ACERO / ACIER

OP.2 WOOD / MADERA / BOIS

■ FINISHES / ACABADOS / FINITIONS

WENGUE		
CHERRY	CEREZO	MERISIER
OAK	ROBLE	CHÊNE
WALNUT	NOGAL	NOIR
STAINLESS STEEL	ACERO INOX	ACIER INOX

■ BUTTON / BOTÓN / BOUTON

- Upholstered button in pulls.
- Botón tapizado en los tirones.
- Bouton tapissé dans le tirers.



REF.

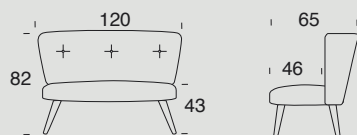

9862B

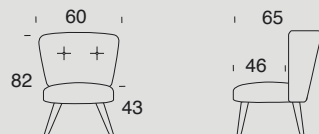

986BU



986SI

OPTIONS / OPCIONES / OPTIONS

■ FINISHES / ACABADOS / FINITIONS

WENGUE

CHERRY CEREZO MERISIER

OAK ROBLE CHÊNE

WALNUT NOGAL NOYER

■ BUTTON / BOTÓN / BOUTON

.Upholstered button in pulls. Specify the color of the button fabric.  
 .Botón tapizado en los tirones. Especificar el color del tejido del botón.  
 .Bouton tapissé dans le tirers. Spécifier la couleur du tissu du bouton.



REF.

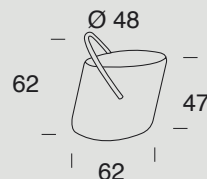

966BU

OPTIONS / OPCIONES / OPTIONS

■ HANDLE FINISHES / ACABADOS RESPALDO / FINITIONS DOSSIER

HANDLE WOOD OPTION OPCIÓN ASA DE MADERA OPTION EN BOIS	WENGUE		
	CHERRY	CEREZO	MERISIER
OAK	ROBLE	CHÊNE	
AISI 304	AISI 304 STEEL	ACERO AISI 304	ACIER AISI 304



REF.

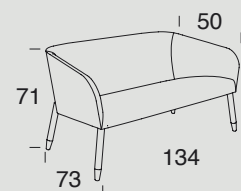

9912P

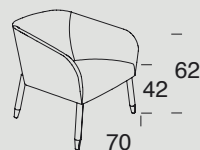

991BU

OPTIONS / OPCIONES / OPTIONS

■ FINISHES / ACABADOS / FINITIONS

WENGUE

CHERRY CEREZO MERISIER

WALNUT NOGAL NOYER

OAK ROBLE CHÊNE



REF.

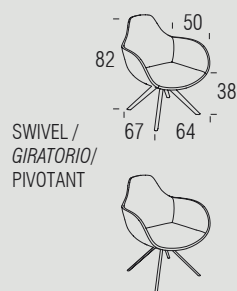

226BM

SWIVEL / GIRATORIO / PIVOTANT



226BT

OPTIONS / OPCIONES / OPTIONS

■ BASEBOARD / BASE / SOCLE

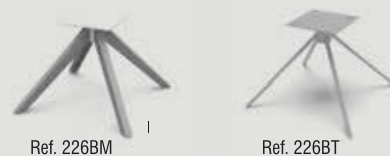

Ref. 226BM

Ref. 226BT

■ FINISHES / ACABADOS / FINITIONS

Ref.226BM WENGUE

Ref.226BM WALNUT NOGAL NOYER

Ref.226BM ASH FRESNO FRÊNE

Ref.226BM OAK ROBLE CHÊNE

Ref.226BT WHITE BLANCO BLANC

Ref.226BT BLACK NEGRO NOIR

Ref.226BT COPPER COBRE CUIVRE



REF.

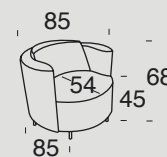

946B1



946B2



946B3

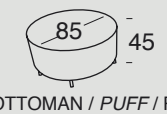

946P1

OTTOMAN / PUFF / PUFF



946P2

OTTOMAN / PUFF / PUFF

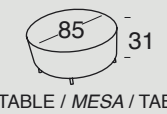

946M1

TABLE / MESA / TABLE

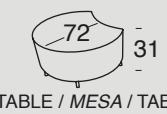

946M2

TABLE / MESA / TABLE

■ EXAMPLES / EJEMPLOS / EXEMPLES



OPTIONS / OPCIONES / OPTIONS

■ FINISHES / ACABADOS / FINITIONS

LAQUERED / LACADO / LAQUÉ

BLACK, WHITE, RED, NEGRO, BLANCO, ROJO, NOIR, BLANC, ROUGE,

STONE, GREY, SEA, GREEN, PIEDRA, GRIS, MAR, PIERRE, GREY, MER, VERT,

FUCHSIA, ORANGE, VERDE, FUCHSIA, NARANJA, FUCHSIA, ORANGE,

SEE FINISHES TABLE ENCLOSED VER TABLA DE ACABADOS VOIR TABLEAU DES FINITIONS

ANTI SCRATCH ANTIRALLADURA ANTIRÂPURE



REF.

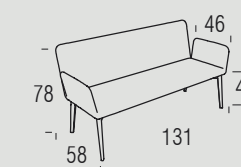

2272B

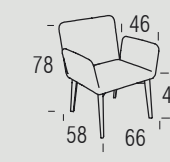

227BU

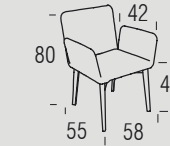

227SI

OPTIONS / OPCIONES / OPTIONS

■ FINISHES / ACABADOS / FINITIONS

WENGUE

CHERRY CEREZO MERISIER

OAK ROBLE CHÊNE

WALNUT NOGAL NOYER

ASH FRESNO FRÊNE

■ STITCHING / COSTURA / COUTURE

.Indicate the colour of the decorative piping.  
 .Indicar el color del vivo decorativo.  
 .Définir la couleur du passepoil décorative.



REF.

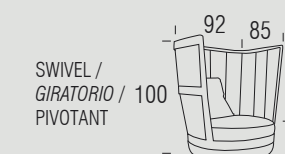

978BU

SWIVEL / GIRATORIO / 100 PIVOTANT

OPTIONS / OPCIONES / OPTIONS

■ STRUCTURE FINISHES / ACABADOS ESTRUCTURA / FINITIONS DU STRUCTURE

BLANCO BRILLO O MATE WHITE SHINE OR MATT BLANC BRILLIANT OU MAT

NEGRO BRILLO O MATE BLACK SHINE OR MATT BNOIR BRILLIANT OU MAT

ASK FOR AVAILABLE COLOURS BY QUANTITY.  
 CONSULTE DISPONIBILIDAD DE COLORES POR CANTIDADES.  
 CONSULTER DISPONIBILITÉ DE COULEURS POUR QUANTITÉS.



REF.

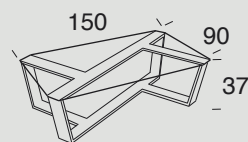

83116

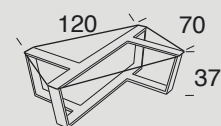

83112

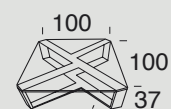

83110

**OPTIONS / OPCIONES / OPTIONS**

## ■ FINISHES / ACABADOS / FINITIONS

WOOD / MADERA / BOIS

WENGUE

CHERRY *CEREZO* MERISIEROAK *ROBLE* CHÊNEWALNUT *NOGAL* NOYER

## LACQUERED / LACADO / LAQUÉ

BLACK, WHITE *NEGRO, BLANCO* NOIR, BLANCSTONE, GREY, SEA, *PIEDRA, GRIS, MAR,* PIERRE, GREY, MER,GREEN, FUCHSIA, *VERDE, FUCSIA,* VERT, FUCHSIA,SEE FINISHES TABLE ENCLOSED / *VER TABLA DE ACABADOS* VOIR TABLEAU DES FINITIONS

REF.

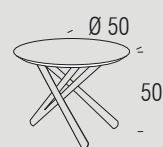

83250

**OPTIONS / OPCIONES / OPTIONS**

## ■ FINISHES / ACABADOS / FINITIONS

WOOD / MADERA / BOIS

WENGUE

CHERRY *CEREZO* MERISIEROAK *ROBLE* CHÊNEWALNUT *NOGAL* NOYER

## LACQUERED / LACADO / LAQUÉ

BLACK, WHITE *NEGRO, BLANCO* NOIR, BLANCSTONE, GREY, SEA, *PIEDRA, GRIS, MAR,* PIERRE, GREY, MER,GREEN, FUCHSIA, *VERDE, FUCSIA,* VERT, FUCHSIA,SEE FINISHES TABLE ENCLOSED / *VER TABLA DE ACABADOS* VOIR TABLEAU DES FINITIONS

REF.

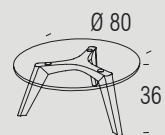

86380

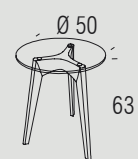

86350

**OPTIONS / OPCIONES / OPTIONS**

## ■ FINISHES / ACABADOS / FINITIONS

WENGUE

CHERRY *CEREZO* MERISIERASH *FRESNO* FRÊNEWALNUT *NOGAL* NOYEROAK *ROBLE* CHÊNE

REF.



83840

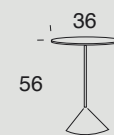

83847

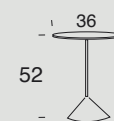

83844

**OPTIONS / OPCIONES / OPTIONS**

## ■ FINISHES / ACABADOS / FINITIONS

WOOD / MADERA / BOIS

WENGUE

CHERRY *CEREZO* MERISIERSYCAMORE *SICOMORO* SYCOMOREWALNUT *NOGAL* NOYEROAK *ROBLE* CHÊNE

## LACQUERED / LACADO / LAQUÉ

BLACK, WHITE *NEGRO, BLANCO* NOIR, BLANCSTONE, GREY, SEA, *PIEDRA, GRIS, MAR,* PIERRE, GREY, MER,GREEN, FUCHSIA, *VERDE, FUCSIA,* VERT, FUCHSIA,SEE FINISHES TABLE ENCLOSED / *VER TABLA DE ACABADOS* VOIR TABLEAU DES FINITIONS

REF.

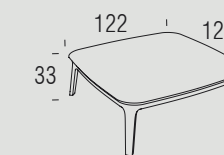

98512

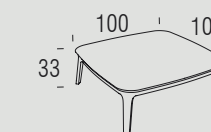

98510

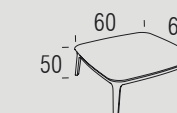

98560

**OPTIONS / OPCIONES / OPTIONS**

## ■ FINISHES / ACABADOS / FINITIONS

WOOD / MADERA / BOIS

WENGUE

CHERRY *CEREZO* MERISIERASH *FRESNO* FRÊNEWALNUT *NOGAL* NOYEROAK *ROBLE* CHÊNE

## MARBLE / MARMÓL / MARBRE

WHITE *BLANCO* BLANCBLACK *NEGRO* NOIRBROWN *MARRÓN IMPERIAL* BRUN



REF.

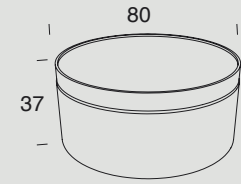

83780

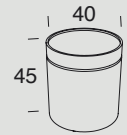

83740

## OPTIONS / OPCIONES / OPTIONS

## ■ FINISHES / ACABADOS / FINITIONS

WALNUT	NOGAL	NOYER
ASH	FRESNO	FRÊNER
WENGUE		
OAK	ROBLE	CHÊNE



REF.

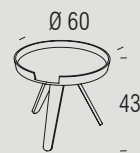

84160

## OPTIONS / OPCIONES / OPTIONS

## ■ FINISHES / ACABADOS / FINITIONS

WENGUE		
CHERRY	CEREZO	MERISIER
OAK	ROBLE	CHÊNE
WALNUT	NOGAL	NOYER



REF.

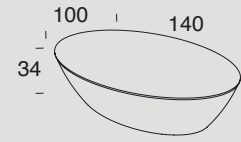

83914

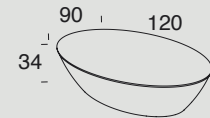

83912

## OPTIONS / OPCIONES / OPTIONS

## ■ FINISHES / ACABADOS / FINITIONS

TOP / SOBRE / PANNEAU		
WOOD / MADERA / BOIS		
WENGUE		
CHERRY	CEREZO	MERISIER
WALNUT	NOGAL	NOYER
OAK	ROBLE	CHÊNE
MARBLE / MARMÓL / MARBRE		
WHITE	BLANCO	BLANC
BLACK	NEGRO	NOIR
BROWN	MARRÓN IMPERIAL	BRUN
BASE		
LACQUERED / LACADO / LAQUÉ		
BLACK, WHITE	NEGRO, BLANCO	NOIR, BLANC
STONE, GREY, SEA,	PIEDRA, GRIS, MAR,	PIERRE, GREY, MER,
GREEN, FUCHSIA,	VERDE, FUCSIA,	VERT, FUCHSIA,
SEE FINISHES TABLE ENCLOSED	VER TABLA DE ACABADOS	VOIR TABLEAU DES FINITIONS



REF.

MESA / TABLE

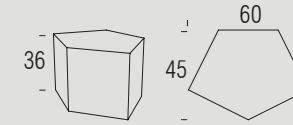

99230

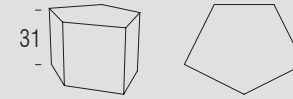

99231

POUFF / OTTOMAN

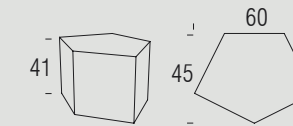

992PF

## OPTIONS / OPCIONES / OPTIONS

## ■ FINISHES / ACABADOS / FINITIONS

WOOD / MADERA / BOIS

WENGUE

CHERRY	CEREZO	MERISIER
OAK	ROBLE	CHÊNE
WALNUT	NOGAL	NOYER

LACQUERED / LACADO / LAQUÉ

BLACK, WHITE	NEGRO, BLANCO	NOIR, BLANC
STONE, GREY, SEA,	PIEDRA, GRIS, MAR,	PIERRE, GREY, MER,
GREEN, FUCHSIA,	VERDE, FUCSIA,	VERT, FUCHSIA,

SEE FINISHES TABLE ENCLOSED VER TABLA DE ACABADOS VOIR TABLEAU DES FINITIONS



REF.

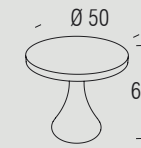

836ME

## OPTIONS / OPCIONES / OPTIONS

## ■ FINISHES / ACABADOS / FINITIONS

WOOD / MADERA / BOIS

WENGUE

CHERRY	CEREZO	MERISIER
OAK	ROBLE	CHÊNE
WALNUT	NOGAL	NOYER

LACQUERED / LACADO / LAQUÉ

BLACK, WHITE	NEGRO, BLANCO	NOIR, BLANC
STONE, GREY, SEA,	PIEDRA, GRIS, MAR,	PIERRE, GREY, MER,
GREEN, FUCHSIA,	VERDE, FUCSIA,	VERT, FUCHSIA,

SEE FINISHES TABLE ENCLOSED VER TABLA DE ACABADOS VOIR TABLEAU DES FINITIONS



WOOD TOP

REF.



GLASS TOP

WOOD TOP

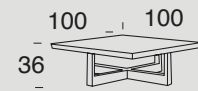

82810

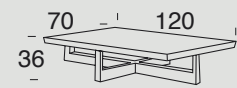

82812

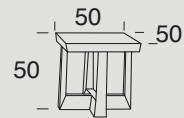

82860



82811



82813

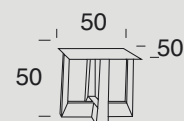

82861

**OPTIONS / OPCIONES / OPTIONS**

■ FINISHES / ACABADOS / FINITIONS

WALNUT      NOGAL      NOYER



REF.



83479



83459



83448

**OPTIONS / OPCIONES / OPTIONS**

■ FINISHES / ACABADOS / FINITIONS

WOOD / MADERA / BOIS

WENGUE

CHERRY      CEREZO      MERISIER

OAK      ROBLE      CHÊNE

WALNUT      NOGAL      NOYER

LACQUERED / LACADO / LAQUÉ

BLACK, WHITE      NEGRO, BLANCO      NOIR, BLANC

STONE, GREY, SEA,      PIEDRA, GRIS, MAR,      PIERRE, GREY, MER,

GREEN, FUCHSIA,      VERDE, FUCSIA,      VERT, FUCHSIA,

SEE FINISHES TABLE ENCLOSED      VER TABLA DE ACABADOS      VOIR TABLEAU DES FINITIONS



REF.

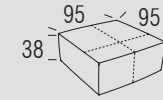

86510



86550

**OPTIONS / OPCIONES / OPTIONS**

■ STITCHING / COSTURA / COUTURE

Indicate the colour of the decorative stitching thread.  
Definir el color del hilo de la costura decorativa.  
Définir la couleur du fil de la couture décorative.

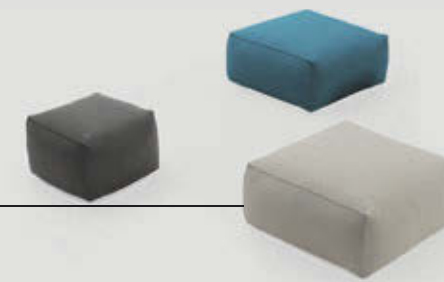

REF.

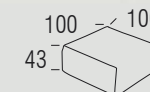

97310

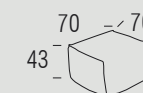

97370

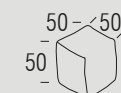

97350



REF. 974DB

REF. 955CO

REF. 969CO

REF. 974ME

REF. 940CO

REF. 964CO

REF.

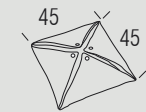

974DB

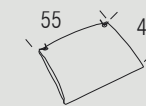

974ME

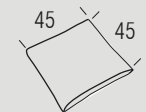

969CO

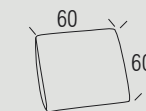

940RE

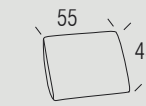

940CO

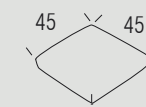

955CO

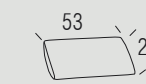

964CO

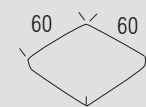

970CO



FRAJUMAR®

Handmade  
Upholstery in

SPAIN

# INDEX FRAJUMAR

## SOFA



**BASIK 138-141\_Tc 196**



**COOL 142-145\_Tc 196**



**COSY 124-125\_Tc 197**



**EGOS 134-135\_Tc 197**



**EMUC 146-149\_Tc 198**



**GINA 162-165\_Tc 198**



**KIRK 152-155\_Tc 199**



**LIME 160-161\_Tc 199**



**LOBI 150-151\_Tc 199**



**MOMA 126-127\_Tc 200**



**MUSA 158-159\_Tc 200**



**MYMA 156-157\_Tc 201**



**NIMO 136-137\_Tc 201**



**PAIR 166-167\_Tc 202**



**SOUL 132-133\_Tc 202**

## RELAX



**KLAS 128-131\_Tc 203**



**EGAN 176\_Tc 203**



**MILO 177\_Tc 203**

## SOFA BED



**DARO 172-173\_Tc 204**



**CORA 168-169\_Tc 204**



**MUKA 174-175\_Tc 205**



**TRUE 170-171\_Tc 205**

## ARMCHAIR



**ALMA 185\_Tc 206**



**CITY 182\_Tc 206**



**IOVA 186\_Tc 206**



**LASE 183\_Tc 206**



**OFRE 180-181\_Tc 207**



**ONLY 178-179\_Tc 207**



**SALO 184\_Tc 207**



**TOMO 188\_Tc 207**



**VERA 187\_Tc 208**



**VINA 189\_Tc 208**

## TABLE



**ALO 190\_Tc 208**



**GIB 191\_Tc 208**



**RING 192\_Tc 209**



**SAIL 193\_Tc 209**

## COMPLEMENT



**CUBE 194\_Tc 209**



**CUSHIONS 195\_Tc 209**

FABRICS / TEJIDOS / TISSUS 210-212

FINISHES / ACABADOS / FINITIONS 213





**COSY** sofa, *sofá, canapé*. **EVEN** armchair, *butaca, fauteuil*

Synonymous  
with a good  
sofa

**COSY**  
Design Arbel



# Indisputed personality

Refined elegance, precious details, are the unique expression of the design requested by contemporary trends that adapt to all contexts, giving the space where is placed an indisputable personality. Sofa with wide modular range, allowing all kinds of compositions for the home.

*La refinada elegancia, los detalles preciosos, son la expresión única del diseño solicitado por las tendencias contemporáneas que se adaptan a todos los contextos, dando al espacio en que se encuentra una personalidad indiscutible. Sofá de amplia variedad modular, permitiendo todo tipo de composiciones para el hogar.*

L'élégance raffinée, les détails précieux, sont l'expression unique du concept sollicité par les tendances contemporaines qui s'adaptent à tous les contextes, en donnant à l'espace dans lequel il se trouve une personnalité indiscutable. Canapé d'une grande variété modulaire qui permet tous les types de compositions pour la maison.

## MOMA

Design Arbel



MOMA sofa, sofá, canapé. ONLY armchair, butaca, fauteuil. GIB table, mesa



KLAS sofa, sofá, canapé. ALMA armchair, butaca, fauteuil



KLAS sofa, sofà, canapé. ALMA armchair, butacă, fauteuil

# Relax sofa for the most demanding customer

**The relax sofa Klas is the answer that Frajumar offers to all of those searching a special comfort with the highest quality.**

El sofa relax Klas es la respuesta que Frajumar ofrece a todos aquellos que buscan una comodidad especial con la mayor calidad.

Le canapé relax Klas est la réponse que Frajumar offre à tous ceux qui cherchent la confort dans toutes ces sensations avec la meilleur qualité .

**KLAS**  
Design Arbel



# Comfort and functionality

Balance between aesthetics, comfort of the seating area along with a structural geometry of straight lines and small size, offer the possibility of integrating Soul in any environment.

*Equilibrio entre estética, comodidad y funcionalidad. La gran amplitud y comodidad de sus almohadas junto a una geometría estructural de líneas rectas y dimensiones reducidas, ofrecen la posibilidad de integrar Soul en cualquier ambiente.*

Équilibre entre esthétique, confort et fonctionnalité. L'espace et le confort des oreillers avec une géométrie structurale des lignes droites et petites, offrent la possibilité d'intégrer le SOUL dans n'importe quel environnement.

## SOUL

Design Alejandro Azorín



SOUL sofa, sofá, canapé. FRES table, mesa

Where  
details  
are  
important

**EGOS**  
Design Arbel



OP. 1



OP. 2



EGOS sofa, sofà, canapé. LASE armchair, butaca, fauteuil

# Strength and comfort

**Contemporary model in which the compact forms confer strength and comfort. The thick seat features an elastic sitting that adapts perfectly to different anatomies.**

*Modelo de línea actual en el que las formas compactas le atribuyen solidez y confort. El asiento, de gran espesor, ofrece una sentada elástica que se adapta a la perfección a distintas anatomías.*

Le modèle est d'une ligne actuelle avec des formes compactes qui lui ajoute solidité et confort. Le siège, d'une grande épaisseur, offre une assise élastique qui s'adapte à la perfection aux différentes anatomies.

**NIMO**  
Design Arbel



# Straight and elegant shapes

**BASIK**  
Design Arbel



BASIK sofa, *sofá*, canapé. ALO table, *mesa*



LASE armchair, *sillón*, fauteuil





BASIK sofa, sofá, canapé. CITY armchair, butaca, fauteuil

# Variety of modules

Cool is a very functional model with a wide variety of modules for combination. Its simplicity invites playing with colours and textures.

*Cool es un modelo que destaca por su funcionalidad y por la amplia variedad de combinaciones que se pueden obtener a partir de sus módulos. Su sencillez invita a jugar con los colores y las texturas.*

Cool est un modèle qui s'intensifie par sa fonctionnalité et par l'ample variété de combinaisons qui peuvent être obtenus à partir de ses modules. Sa simplicité invite à jouer avec les couleurs et les textures.

## COOL

Design Arbel

OP. 1 



OP. 2 



COOL sofa, sofá, canapé. RAÍZ table, mesa



COOL sofa, sofà, canapé. RAÍZ table, mesa

# Comfort and seclusion

This model highlights the rounded cushion shapes. Large volumes that inspire comfort and seclusion.

*Emuc modelo en el que destaca las formas redondeadas de sus almohadas, amplios volúmenes que inspiran confort y recogimiento.*

Le modèle Emuc se fait remarquer par les formes arrondies de ses coussins, amples volumes qui inspirent confort et recueillement.

## EMUC

Design Arbel



EMUC sofa, sofà, canapé. SALO armchair, butaca, fauteuil. BACK table, mesa



EMUC sofa, sofá, canapé. **BACK** armchair, butaca, fauteuil. **BACK** table, mesa

# Elegant and majestic

**LOBI**  
Design Arbel



LOBI sofa, sofá, canapé. GIB table, mēsa



KIRK sofa, sofá, canapé. BLOM armchair, butaca, fauteuil



KIRK sofa, sofá, canapé. BLOM armchair, butaca, fauteuil

# Classic with vintage flavor

**KIRK**  
Design Arbel





Sophisticated  
and exclusive  
design

**MYMA**  
Design Arbel



# Classic environment

**Classical shape sofa. Large cylindrical arms and turned legs make it ideal for the decoration of the more conservative environments.**

*Sofá de aspecto clásico, los grandes brazos cilíndricos y las patas torneadas le hacen idóneo para la decoración de los entornos más conservadores.*

*Canapé d'un air classique, les grands accoudoirs cylindriques et le piètement tourné le rendent idéal pour la décoration des ambiances plus conservatrices.*

## MUSA

Design Arbel



Removable



MUSA sofa, sofá, canapé. EVEN table, mesa

# Offers a different solution

Proposal that shows accurately the classical geometrics. It is a visual surprise for its size thanks to its slender chrome plated steel legs. It offers a different solution for most contemporary spaces.

*Propuesta que reinterpreta el clásico rigor geométrico, sorprende visualmente por sus proporciones gracias a sus esbeltas patas de acero cromado. Ofrece una respuesta diferente a los espacios más contemporáneos.*

Proposition qui réinterprète la rigueur géométrique classique, il nous surpris avec ses proportions grâce à ses pieds fins en acier chromé. Il offre une réponse différente aux espaces contemporains.

## LIME

Design Arbel



LIME sofa, sofà, canapé. AGOL table, mesa

# Great Comfort

The main feature of this model is its great comfort. The inclination of the arm along with its pillow provides a comfortable resting position if we want to remain lying.

*La principal característica de este modelo es su gran confortabilidad. La inclinación del brazo junto con su almohada proporciona una cómoda posición de descanso si queremos permanecer tumbados.*

La principale caractéristique de ce modèle est son grand confort. L'inclinaison du bras avec son coussin fournit une position commode de repos si nous voulons rester étendus.

**GINA**  
Design Arbel



GINA sofa, sofá, canapé. LIAM pouff



GINA sofa, sofá, canapé. LIAM pouff. EGAN relax armchair, butaca relax, fauteuil relax

# Sofa with own style

**PAIR**  
Design Arbel



PAIR sofa, sofă, canapé. MILO relax armchair, butaca relax, fauteuil relax. GIB table, mesa



CORA sofa-bed, sofa cama, canapé lit.

# The compact multifunctional solution

**CORA**  
Design Arbel



# Casual and Timeless

**Contemporary sofa bed, lightweight appearance thanks to feet height. Designed for all types of spaces either at home or at contract spaces.**

*Sofá cama de aspecto contemporáneo, ligero gracias a la altura de patas, pensado para todo tipo de espacios ya sea en el hogar o para espacios contract*

Sa ligne est élégante et moderne, il représente une prouesse technique élaborée par notre bureau d'études pour répondre à vos attentes en matière de design, de confort et d'innovation.

**TRUE**  
Design Arbel



**TRUE sofa-bed, sofá-cama, canapé lit. OPEN table, mesa. IOVA armchair, butaca, fauteuil.**





OPTION A



OPTION B



OPTION C



OPTION D



# Functional and nice solution

**DARO**  
Design Arbel



DARO sofa-bed, sofá cama, convertible



Pure lines,  
minimalist  
style

**MUKA**  
Design Arbel



MUKA sofa-bed, sofà cama, canapé lit

**EGAN**  
Design Majo Tumini



The  
relax  
concept

**MILO**  
Design Majo Tumini



# Details make the difference

## **ONLY**

Design Robert Ortega



# Distinction and elegance

Its main characteristic are the inclined planes. Arm, back and seat take one position, offering comfort, distinction and elegance.

Su principal particularidad es el uso de planos inclinados. Brazo-respaldo y asiento adoptan una posición, ofreciendo confortabilidad, distinción y elegancia.

Sa particularité principale est l'utilisation de plans inclinés. Bras-dossier et assise adoptent une position qui offre confort, distinction et élégance.

## OFRE

Design Eduardo Climent



**CITY**

Design Eduardo Climent



Wraparound  
shapes

**LASE**

Design Arbel



**SALO**  
Design Arbel



**ALMA**  
Design Arbel



# Classical look

**IOVA**  
Design Arbel



**VERA**  
Design Arbel



**TOMO**  
Design Arbel



Ideal  
armchairs  
for contract  
spaces

**VINA**  
Design Eduardo Climent



# Craft Makers

**ALO**  
Design Arbel



**GIB**  
Design Arbel





**RING**  
Design Arbel



**SAIL**  
Design Arbel

# Casual elegance

**CUBE**  
Design Arbel



## CUSHIONS and DECORATION

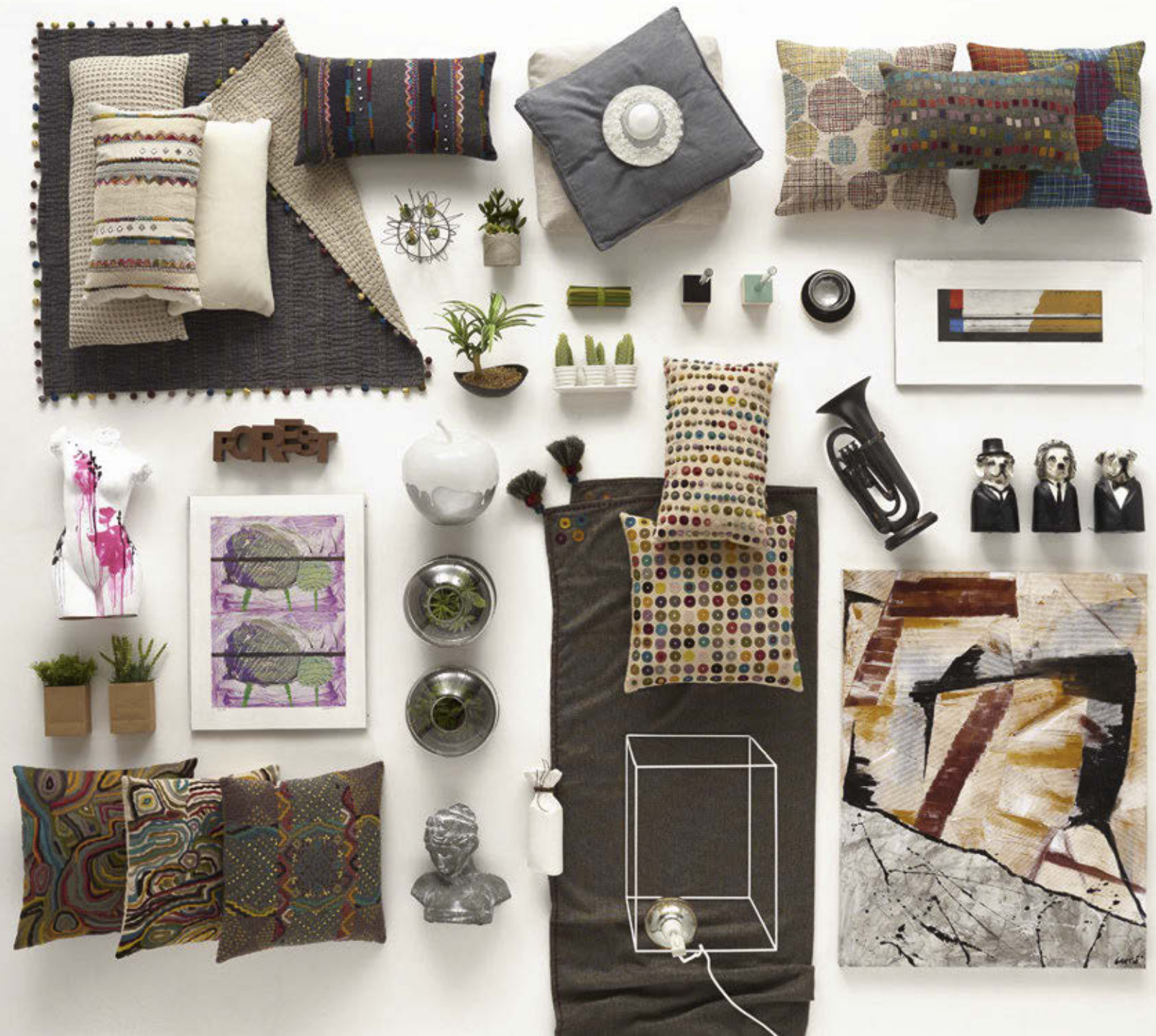



REF.



**1844P**

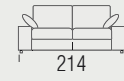

**1843P**

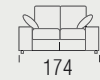

**1842P**

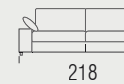

**184M4**

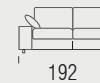

**184M3**



**184M2**

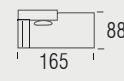

**184CH**

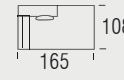

**184CS**

**OPTIONS / OPCIONES / OPTIONS**

■ SEATS / ASIENTOS/ ASSISES



DOWN TOUCH / PLUMÓN / TACT DUVET

■ LEGS / PATAS / PIEDS



HIDDEN / OCULTA

■ FINISHES / ACABADOS / FINITIONS

P-25, P42 WENGUE

P-25 CHERRY CEREZO MERISIER

P-25 OAK ROBLE CHÊNE

P-10 CHROMED CROMADO CHROMÉ



OP.1



OP.2

REF.

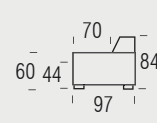

**201EP**

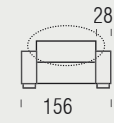

**2011P**



**201ME**



**201M1**



**201ES**



**2011S**



**201CH**

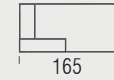

**201CS**



**201PR**



**201RI**



**OPTIONS / OPCIONES / OPTIONS**

■ LEGS / PATAS / PIEDES



HIDDEN / OCULTA

■ FINISHES / ACABADOS / FINITIONS

P-42 WENGUE



REF.

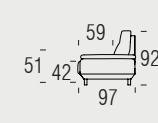

**1294P**

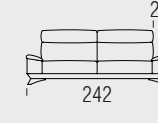

**1293P**

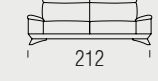

**1292P**

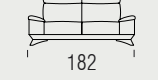

**1291P**



**129M4**

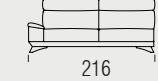

**129M3**

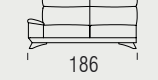

**129M2**



**129ME**



**129M1**



**129CH**

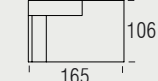

**OPTIONS / OPCIONES / OPTIONS**

■ LEGS / PATAS / PIEDS

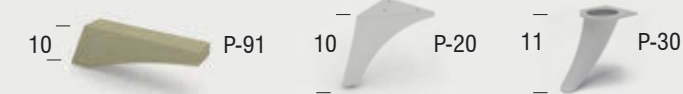

■ FINISHES / ACABADOS / FINITIONS

P-91 WENGUE

P-91 CHERRY CEREZO MERISIER

P-91 OAK ROBLE CHÊNE

P-20, P30 CHROMED CROMADO CHROMÉ



REF.

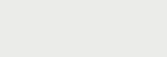
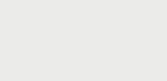
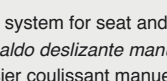
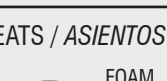
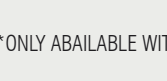
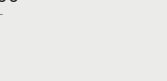
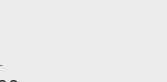
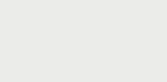
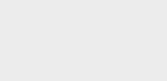
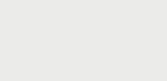
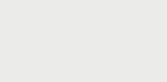
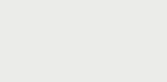
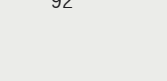
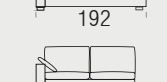
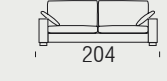
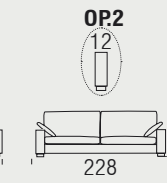
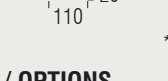
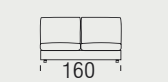
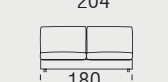
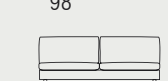
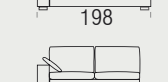
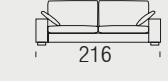
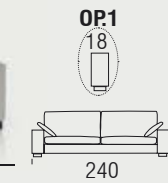

\* ONLY AVAILABLE WITH OPTION 1

**OPTIONS / OPCIONES / OPTIONS**

■ LEGS / PATAS / PIEDS

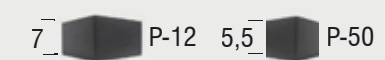

FOAM GOMA MOUSSE

■ SLIDING / DESLIZANTE / AMOVIBLE

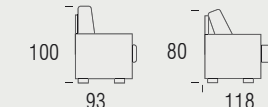

- Manual sliding system for seat and back.  
- Asiento y respaldo deslizante manual.  
- Assise et dossier coulissant manuel.

	<b>OP1</b> 30 264	<b>OP2</b> 20 244	<b>REF.</b>
	240	220	<b>1785P</b>
	220	200	<b>1784P</b>
	180	160	<b>1783P</b>
	125	105	<b>1782P</b>
	125	105	<b>1781P</b>
	234	224	<b>178M5</b>
	210	200	<b>178M4</b>
	190	180	<b>178M3</b>
	150	140	<b>178M2</b>
	110	100	<b>178ME</b>
	95	85	<b>178M1</b>
	204		<b>1785S</b>
	180		<b>1784S</b>
	160		<b>1783S</b>
	120		<b>1782S</b>
	80		<b>178ES</b>
	65		<b>1781S</b>
	165	165	<b>178CH</b>
	165	165	<b>178CS</b>
	195		<b>178CR</b>
	110	80	<b>178PF</b>
	110	80	<b>178RI</b>

**OPTIONS / OPCIONES / OPTIONS**

- LEGS / PATAS / PIEDS
- SEATS / ASIENTOS / ASSISE



- SLIDING / DESLIZANTE / AMOVIBLE

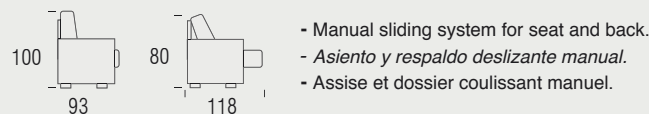

	80 113	86 128	93 138	<b>REF.</b>
				<b>7144P</b>
				<b>7143P</b>
				<b>7142P</b>
				<b>7141P</b>
				<b>714M4</b>
				<b>714M3</b>
				<b>714M2</b>
				<b>714M1</b>
				<b>7144S</b>
				<b>7143S</b>
				<b>7142S</b>
				<b>7141S</b>
				<b>714CH</b>
				<b>714CR</b>
				<b>714RI</b>

**OPTIONS / OPCIONES / OPTIONS**

- LEGS / PATAS / PIEDS

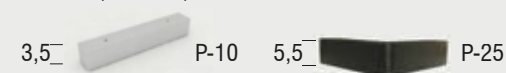

- FINISHES / ACABADOS / FINITIONS

P-25	WENGUE		
P-25	CHERRY	CEREZO	MERISIER
P-25	OAK	ROBLE	CHÊNE
P-10	CHROMED	CROMADO	CHROMÉ

MANUAL SLIDING SYSTEM INCLUDED. BACK RECLINING SYSTEM.  
 DESLIZANTE MANUAL INCLUIDO. RESPALDO ABATIBLE.  
 COULISSANT MANUEL INCLUS DOSSIER À ABATANTS.

	<b>REF.</b>
	<b>7133P</b>
	<b>7132P</b>
	<b>7131P</b>

**OPTIONS / OPCIONES / OPTIONS**

- LEGS / PATAS / PIEDS



- FINISHES / ACABADOS / FINITIONS

P-96	WENGUE		
P-96	CHERRY	CEREZO	MERISIER

	<b>REF.</b>
	<b>9194P</b>
	<b>9193P</b>
	<b>9192P</b>
	<b>919M4</b>
	<b>919M3</b>
	<b>919M2</b>

**OPTIONS / OPCIONES / OPTIONS**

- LEGS / PATAS / PIEDS

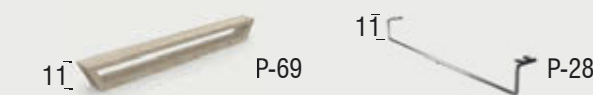

- FINISHES / ACABADOS / FINITIONS

P-69	WENGUE		
P-69	CHERRY	CEREZO	MERISIER
P-69	OAK	ROBLE	CHÊNE
P-28	CHROMED	CROMADO	CHROMÉ

	<b>OP1</b> (2 cushions) 237	<b>OP2</b> (1 cushion) 237	<b>REF.</b>
	212	212	<b>1914P</b>
	172	172	<b>1913P</b>
	107	107	<b>1912P</b>
	216	216	<b>1911P</b>
	191	191	<b>191M4</b>
	151	151	<b>191M3</b>
	86	86	<b>191M2</b>
	86	86	<b>191M1</b>
	165	86	<b>191CH</b>
	165	106	<b>191CS</b>
	90	50	<b>191PF</b>

**OPTIONS / OPCIONES / OPTIONS**

- LEGS / PATAS / PIEDS
- SEATS / ASIENTOS / ASSISE

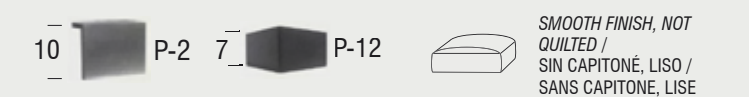

- FINISHES / ACABADOS / FINITIONS

P-12	WENGUE		
P-12	CHERRY	CEREZO	MERISIER
P-12	OAK	ROBLE	CHÊNE
P-2	ALUMINUM	ALUMINIO	ALUMINIUM



REF.

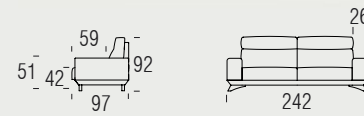

2074P

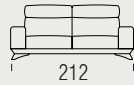

2073P

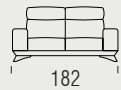

2072P



2071P

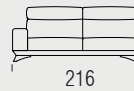

207M4

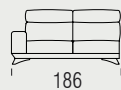

207M3

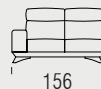

207M2



207ME



207M1

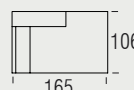

207CH

OPTIONS / OPCIONES / OPTIONS

■ LEGS / PATAS / PIEDS



■ FINISHES / ACABADOS / FINITIONS

P-91	WENGUE		
P-91	CHERRY	CEREZO	MERISIER
P-91	OAK	ROBLE	CHÊNE
P-20, P30	CHROMED	CROMADO	CHROMÉ



OP.1

OP.2

REF.

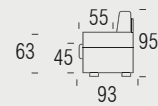

1964P

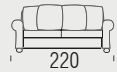
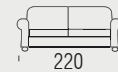
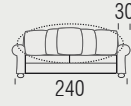
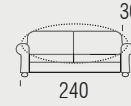

1963P

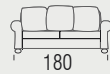
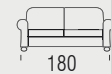

1962P



1961P

OPTIONS / OPCIONES / OPTIONS

■ LEGS / PATAS / PIEDS



■ FINISHES / ACABADOS / FINITIONS

P-33	WENGUE		
P-33	CHERRY	CEREZO	MERISIER
P-33	GOLD LEAF	PAN DE ORO	OR
P-33	SILVER LEAF	PAN DE PLATA	ARGENT

■ SEATS / ASIENTOS / ASSISE



■ REMOVABLE / DESENFUNDABLE / DÉHOUSABLE



REF.



9344P

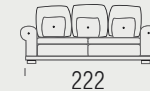

9343P

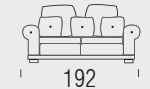

9342P



9341P



9344L



9343L

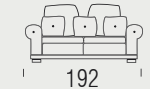

9342L



9341L

OPTIONS / OPCIONES / OPTIONS

■ LEGS / PATAS / PIEDS



■ FINISHES / ACABADOS / FINITIONS

P-34	WENGUE		
P-34	CHERRY	CEREZO	MERISIER
P-34	GOLD LEAF	PAN DE ORO	OR
P-34	SILVER LEAF	PAN DE PLATA	ARGENT
P-34	SHINE BLACK	NEGRO BRILLO	NOIR BRILLANT
P-34	SHINE WHITE	BLANCO BRILLO	BLANC BRILLANT

■ CRYSTALS / CRISTALES / CRISTAUX



Available option for small cushions and front arm.  
Opción disponible para cojines pequeños y frente brazo.  
Option disponible pour coussins et le front des accoudoirs.



REF.

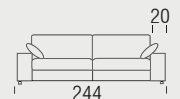

1955P

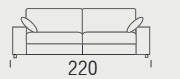

1954P

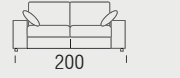

1953P



1952P



1951P

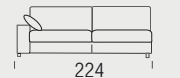

195M5



195M4



195M3



195M2



195ME

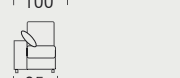

195M1

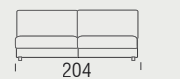

1955S



1954S



1953S



1952S



195ES

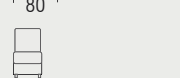

1951S

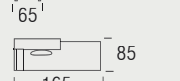

195CH

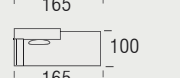

195CS

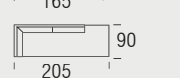

195CR

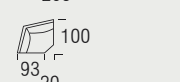

195RI

OPTIONS / OPCIONES / OPTIONS

■ LEGS / PATAS / PIEDS

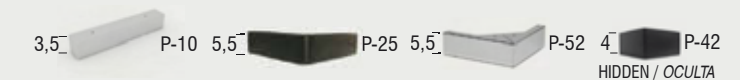

■ SLIDING / DESLIZANTE / AMOVIBLE

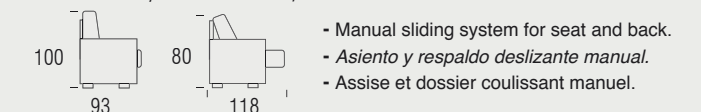

- Manual sliding system for seat and back.  
- Asiento y respaldo deslizante manual.  
- Assise et dossier coulissant manuel.

**PAIR** Arbel 166-167

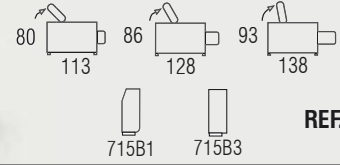

REF.

	<b>7154P</b>
	<b>7153P</b>
	<b>7152P</b>
	<b>7151P</b>
	<b>715M4</b>
	<b>715M3</b>
	<b>715M2</b>
	<b>715M1</b>
	<b>7154S</b>
	<b>7153S</b>
	<b>7152S</b>
	<b>7151S</b>
	<b>715CH</b>
	<b>715CR</b>
	<b>715RI</b>

MANUAL SLIDING SYSTEM INCLUDED. BACK RECLINING SYSTEM.  
 DESLIZANTE MANUAL INCLUIDO. RESPALDO ABATIBLE.  
 COULISSANT MANUEL INCLUS DOSSIER À ABATANTS.

**OPTIONS / OPCIONES / OPTIONS**

■ LEGS / PATAS / PIEDS

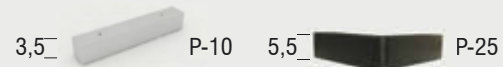

■ FINISHES / ACABADOS / FINITIONS

P-25	WENGUE		
P-25	CHERRY	CEREZO	MERISIER
P-25	OAK	ROBLE	CHÊNE
P-10	CHROMED	CROMADO	CHROMÉ

**SOUL** Arbel 136-137



REF.

	<b>2024P</b>
	<b>2023P</b>
	<b>2022P</b>
	<b>2021P</b>
	<b>202M4</b>
	<b>202M3</b>
	<b>202M2</b>
	<b>202ME</b>
	<b>202M1</b>
	<b>202CH</b>
	<b>202CS</b>
	<b>202RI</b>

**OPTIONS / OPCIONES / OPTIONS**

■ LEGS / PATAS / PIEDS

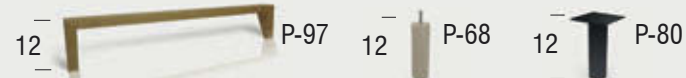

■ FINISHES / ACABADOS / FINITIONS

P-68, P97	WENGUE		
P-68, P97	WALNUT	NOGAL	NOYER
P-68, P97	OAK	ROBLE	CHÊNE
P-80	BLACK	NEGRO	NOIR

**KLAS** Arbel 128-131



REF.

	<b>716ME</b>
	<b>716M1</b>
	<b>716ES</b>
	<b>7161S</b>
	<b>716CH</b>
	<b>716CS</b>

**EGAN** Majo Tumini 176



REF.

SWIVEL / GIRATORIO / PIVOTANT		<b>718BG</b>
FIX / FIJO / FIXE		<b>718BU</b>

**OPTIONS / OPCIONES / OPTIONS**

■ LEGS / PATAS / PIEDS



■ FINISHES / ACABADOS / FINITIONS

Ref. 718BU	WALNUT	NOGAL	NOYER
Ref. 718BU	OAK	ROBLE	CHÊNE
Ref. 718BG	CHROMED	CROMADO	CHROMÉ

**MILO** Majo Tumini 177



REF.

SWIVEL / GIRATORIO / PIVOTANT		<b>717BG</b>
FIX / FIJO / FIXE		<b>717BU</b>

**OPTIONS / OPCIONES / OPTIONS**

■ LEGS / PATAS / PIEDS



■ FINISHES / ACABADOS / FINITIONS

Ref. 717BU	WALNUT	NOGAL	NOYER
Ref. 717BU	OAK	ROBLE	CHÊNE
Ref. 717BG	CHROMED	CROMADO	CHROMÉ





REF.

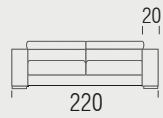

7294P

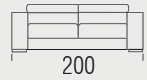

7293P

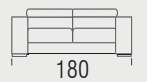

7292P



**OPTIONS / OPCIONES / OPTIONS**

■ MATTRESS / COLCHONES / MATELAS



FOAM  
ESPUMA  
MOUSSE

MEMORY FOAM  
VISCOELÁSTICA  
MÉMOIRE

■ MATTRESS HEIGHT / ALTURA COLCHÓN / HAUTEUR MATELAS

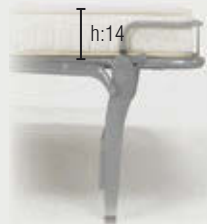

HEIGHT 14 cm  
ALTURA 14 cm  
HAUTEUR 14 cm

■ LEGS / PATAS / PIEDS



■ FINISHES / ACABADOS / FINITIONS

P-25	WENGUE		
P-25	CHERRY	CEREZO	MERISIER
P-25	OAK	ROBLE	CHÊNE



OP. A

OP. B



OP. C

OP. D

REF.

REF.

**OP. A**

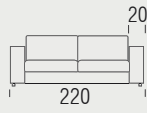

7284A

**OP. C**

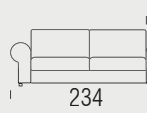

7284C

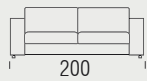

7283A

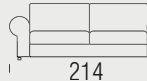

7283C

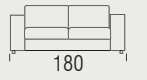

7282A

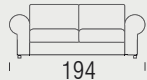

7282C

**OP. B**

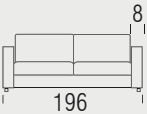

7284B

**OP. D**

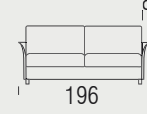

7284D

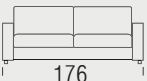

7283B

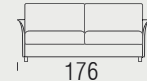

7283D

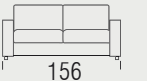

7282B

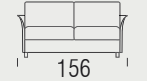

7282D



7281B



7281D

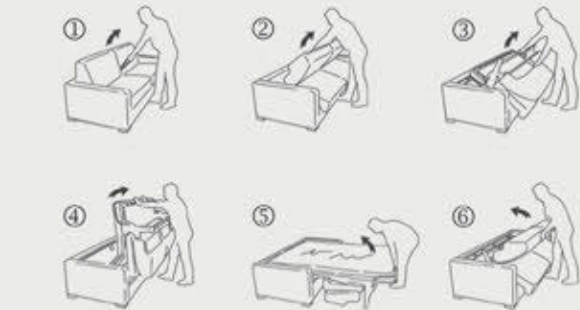

**OPTIONS / OPCIONES / OPTIONS**

■ MATTRESS HEIGHT / ALTURA COLCHÓN / HAUTEUR MATELAS



HEIGHT 14 cm  
ALTURA 14 cm  
HAUTEUR 14 cm



HEIGHT 17 cm  
ALTURA 17 cm  
HAUTEUR 17 cm



REF.

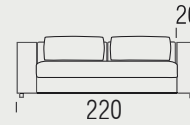

7274P

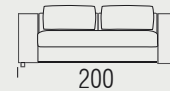

7273P

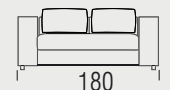

7272P

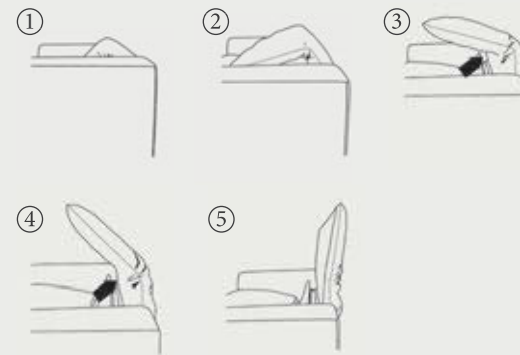

**OPTIONS / OPCIONES / OPTIONS**

■ MATTRESS / COLCHONES / MATELAS



FOAM  
ESPUMA  
MOUSSE

MEMORY FOAM  
VISCOELÁSTICA  
MÉMOIRE

■ MATTRESS HEIGHT / ALTURA COLCHÓN / HAUTEUR MATELAS



HEIGHT 14 cm  
ALTURA 14 cm  
HAUTEUR 14 cm



HEIGHT 17 cm  
ALTURA 17 cm  
HAUTEUR 17 cm



REF.

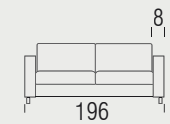

1184P

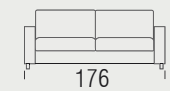

1183P

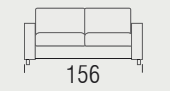

1182P



1181P

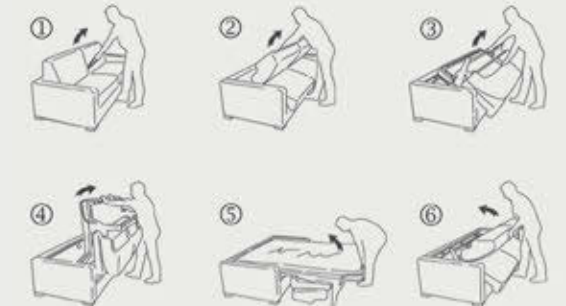
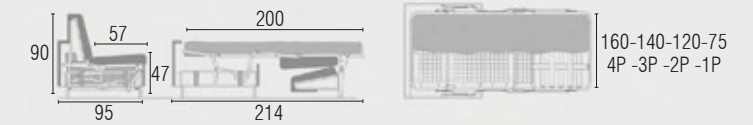

**OPTIONS / OPCIONES / OPTIONS**

■ MATTRESS / COLCHONES / MATELAS



FOAM  
ESPUMA  
MOUSSE

MEMORY FOAM  
VISCOELÁSTICA  
MÉMOIRE

■ MATTRESS HEIGHT / ALTURA COLCHÓN / HAUTEUR MATELAS



HEIGHT 14 cm  
ALTURA 14 cm  
HAUTEUR 14 cm



HEIGHT 17 cm  
ALTURA 17 cm  
HAUTEUR 17 cm



REF.

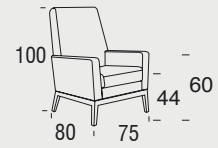

194BZ

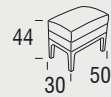

194PF

OPTIONS / OPCIONES / OPTIONS

■ FINISHES / ACABADOS / FINITIONS

WENGUE

CHERRY	CEREZO	MERISIER
OAK	ROBLE	CHÊNE
WALNUT	NOGAL	NOYER



REF.

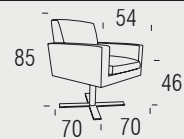

935BU



935BM



935BC



935BP

OPTIONS / OPCIONES / OPTIONS

■ FINISHES / ACABADOS / FINITIONS

935BU	STAINLESS STEEL	ACERO INOX	ACIER INOX
935BM - 935BP	CHERRY	CEREZO	MERISIER
935BM - 935BP	OAK	ROBLE	CHÊNE
935BM - 935BP	WALNUT	NOGAL	NOYER
935BM - 935BP	WENGUE		
935BC (METAL)	WHITE	BLANCO	BLANC
935BC (METAL)	BLACK	NEGRO	NOIR



REF.

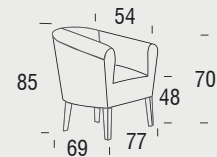

194BU



194BA

OPTIONS / OPCIONES / OPTIONS

■ FINISHES / ACABADOS / FINITIONS

WENGUE

CHERRY	CEREZO	MERISIER
OAK	ROBLE	CHÊNE
WALNUT	NOGAL	NOYER
WHITE	BLANCO	BLANC
MATT BLACK	NEGRO	NOIR



REF.

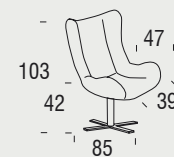

328BU



328BM



328BC

OPTIONS / OPCIONES / OPTIONS

■ FINISHES / ACABADOS / FINITIONS

328BU	STAINLESS STEEL	ACERO INOX	ACIER INOX
328BM	CHERRY	CEREZO	MERISIER
328BM	OAK	ROBLE	CHÊNE
328BM	ASH	FRESNO	FRESNE
328BM	WALNUT	NOGAL	NOYER
328BM	WENGUE		
328BC (METAL)	WHITE	BLANCO	BLANC
328BC (METAL)	BLACK	NEGRO	NOIR



REF.

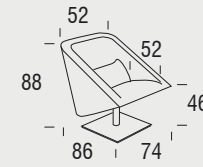

913BU



913BC

FIJO /  
FIX /  
FIXE



913BP

OPTIONS / OPCIONES / OPTIONS

■ FINISHES / ACABADOS / FINITIONS

913BU, 913BP	STAINLESS STEEL	ACERO INOX	ACIER INOX
913BC, 913BP	WHITE	BLANCO	BLANC
913BC, 913BP	BLACK	NEGRO	NOIR



REF.

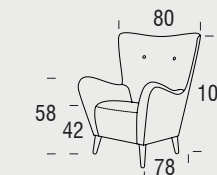

721BU



721PF

OPTIONS / OPCIONES / OPTIONS

■ BUTTON / BOTÓN / BOUTON

Upholstered button in pulls. Specify the color of the button fabric.  
Botón tapizado en los tirones. Especificar el color del tejido del botón.  
Bouton tapissé dans le tirers. Spécifier la couleur du tissu du bouton.

■ FINISHES / ACABADOS / FINITIONS

WENGUE		
CHERRY	CEREZO	MERISIER
OAK	ROBLE	CHÊNE
WALNUT	NOGAL	NOYER



REF.

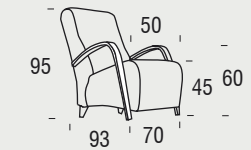

329BU

OPTIONS / OPCIONES / OPTIONS

■ FINISHES / ACABADOS / FINITIONS

WENGUE		
CHERRY	CEREZO	MERISIER
OAK	ROBLE	CHÊNE



REF.

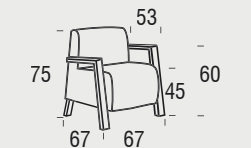

149BU

OPTIONS / OPCIONES / OPTIONS

■ FINISHES / ACABADOS / FINITIONS

WENGUE		
CHERRY	CEREZO	MERISIER
OAK	ROBLE	CHÊNE



REF.

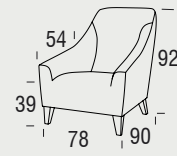

722BU

**OPTIONS / OPCIONES / OPTIONS**

■ FINISHES / ACABADOS / FINITIONS

WENGUE

CHERRY	CEREZO	MERISIER
OAK	ROBLE	CHÊNE
WALNUT	NOGAL	NOYER



REF.

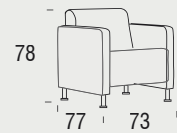

904BU

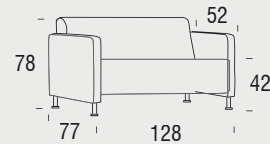

9042P

**OPTIONS / OPCIONES / OPTIONS**

■ LEGS / PATAS / PIEDS



■ FINISHES / ACABADOS / FINITIONS

P-68	WENGUE		
P-68	CHERRY	CEREZO	MERISIER
P-68	OAK	ROBLE	CHÊNE
P-15, P57	CHROMED	CROMADO	CHROMÉ



REF.



82318

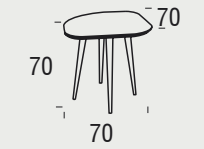

82312

**OPTIONS / OPCIONES / OPTIONS**

■ FINISHES / ACABADOS / FINITIONS

WENGUE

CHERRY	CEREZO	MERISIER
OAK	ROBLE	CHÊNE
WALNUT	NOGAL	NOYER
LACQUERED COLOR	COLOR LACADO	COULEUR LAQUE



OP.1

OP.2

OP.3

REF.

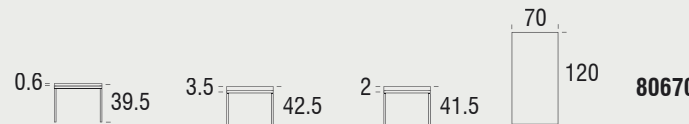

80670

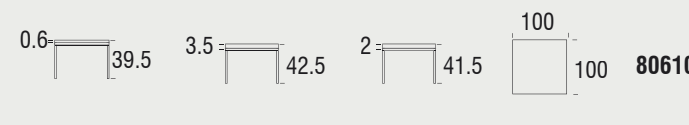

80610

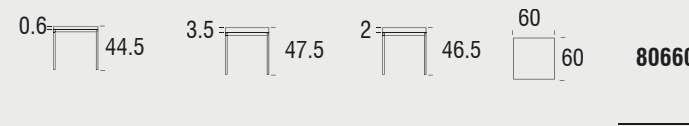

80660

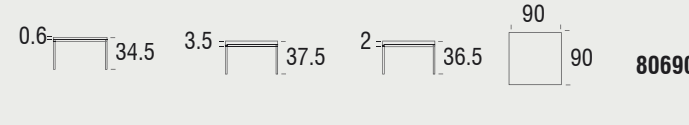

80690

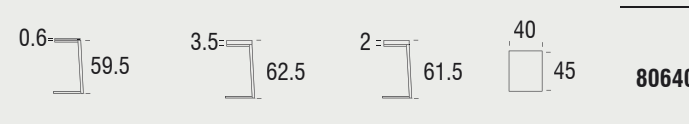

80640

**OPTIONS / OPCIONES / OPTIONS**

■ FINISHES / ACABADOS / FINITIONS

SEE PRICE LIST, VER TARIFA, VOIR TARIF, PAGE 127, PÁGINA 127, PAGE 127



REF.

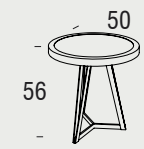

86150

**OPTIONS / OPCIONES / OPTIONS**

■ FINISHES / ACABADOS / FINITIONS

WENGUE

CHERRY	CEREZO	MERISIER
OAK	ROBLE	CHÊNE
WALNUT	NOGAL	NOYER
LACQUERED COLOR	COLOR LACADO	COULEUR LAQUE
SEE FINISHES TABLE	VER TABLA DE	VOIR TABLEAU
ENCLOSED	ACABADOS	DES FINITIONS



REF.

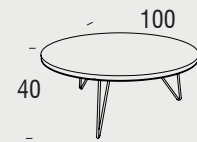

86210

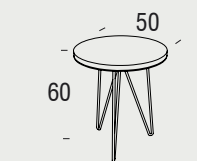

86250

**OPTIONS / OPCIONES / OPTIONS**

■ FINISHES / ACABADOS / FINITIONS

DISTRESSED	MADERA ANTIGUA	VIEUX BOIS
LACQUERED COLOR	COLOR LACADO	COULEUR LAQUE
SEE FINISHES TABLE	VER TABLA DE	VOIR TABLEAU
ENCLOSED	ACABADOS	DES FINITIONS



REF.

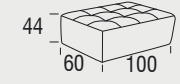

198PE



198PG



198PC



198PA

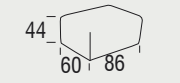

198PN

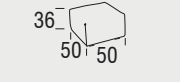

198PF



Ref. 141CO

Ref. 190CO

Ref. 195CO

Ref. REPOS

Ref. 184CO

Ref. 934CO

Ref. 913CO

REF.

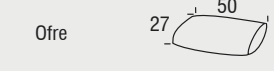

Ofre

913CO

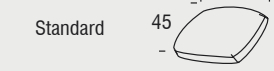

Standard

141CO

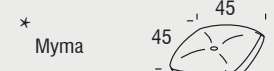

\* Myma

934CO

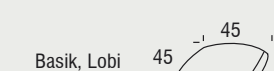

Basik, Lobi

184CO

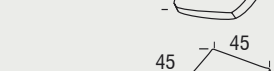

Nimo

195CO

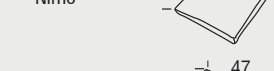

Egos

190CO

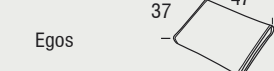

Myma

934CP

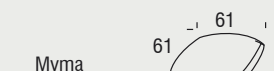

Numa

155CO

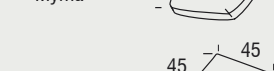

Standard

REPOS

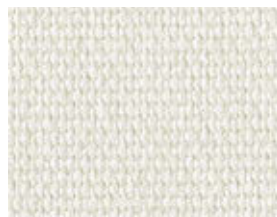

S-1 2644



S-1 2645



S-1 2647



S-1 2648



S-1 2649

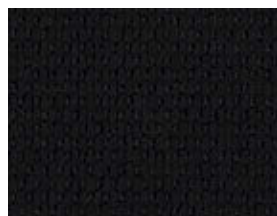

S-1 2650



S-1 2638



S-1 2640



S-1 2641



S-1 2643



S-1 2662



S-1 2663



S-1 2651



S-1 2653



S-1 2658

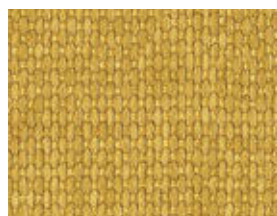

S-1 2659



S-1 2657



S-1 2655



S-1 2654



S-2 5151



S-2 6592



S-2 5152

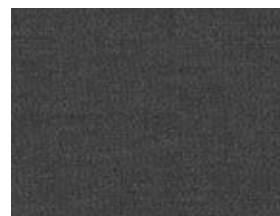

S-2 5153



S-2 5155



S-2 5150

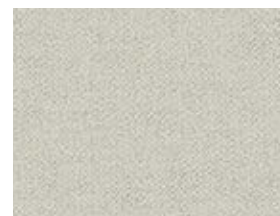

S-2 5149



S-2 5147



S-2 5146



S-2 5145



S-2 5144

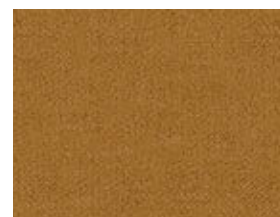

S-2 5141



S-2 5140



S-2 6593



S-2 5142



S-2 5143



S-2 5136



S-2 5137



S-2 5138

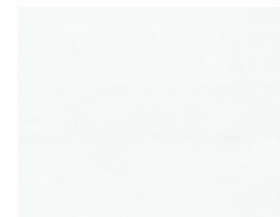

S-2 6594



S-2 6595



S-2 4910



S-2 6596



S-2 4912

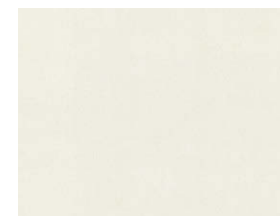

S-2 4897



S-2 4899

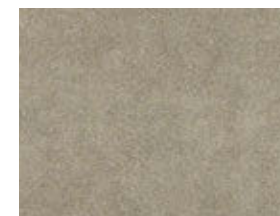

S-2 4900



S-2 4902



S-2 6597



S-2 6598



S-2 4907



S-2 6599



S-2 6600



S-2 6601



S-2 4904



S-2 6602



S-2 4906



S-2 6603

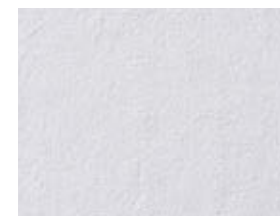

S-3 6602

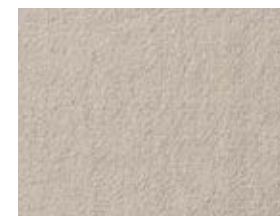

S-3 6603



S-3 6604



S-3 6605



S-3 6606



S-3 6607



S-3 6608



S-3 6609



S-3 6610



S-3 6611



S-3 6612



S-3 6613



S-3 6614



S-3 6615

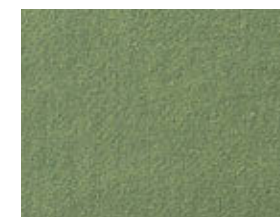

S-3 6616



S-3 6617



S-3 6618



S-3 6619



S-3 6620



ARTÍCULOS ARTICLES	ANCHO WIDTH LARGEUR	COMPOSICIÓN COMPOSITION	RESISTENCIA A LA ABRASIÓN MARTINDALE TEST RÉSISTANCE A L'ABRASION	INSTRUCCIONES DE LAVADO WASHING CARE INSTRUCTIONS DE LAVAGE
S - 1 2638 a 2663	145 cm	100% PES	100000 cycles	
S - 2 5136 a 6593	138 cm	96% PES 4% NY	45000 cycles	
S - 2 4897 a 6603	143 cm	100% PES	100000 cycles	
S - 3 6602 a 6620	140 cm	100% CO	100000 cycles	
S - 2 6604 a 6613	140 cm	47% PES 45% CO 8% RAY	70000 cycles	
S - 4 7265 a 7271	138 cm	100% PL	50000 cycles	
S - 5 8142 a 8159	138 cm	44% VI 16% PL 11% LI 10% WO 9% CO 6% PA 4% SE	25000 cycles ALGUNOS HILOS SUELTOS PARTIAL NON WOVEN THREADS QUELQUES FILS LÂCHES	
S - 5 8160 a 8169	137 cm	40% CO 21% VI 21% PC 18% PL	30000 cycles	
S - 5 8170 a 8179	138 cm	60% LI 40% CO	22000 cycles	

The colors of the fabrics and synthetic leather may differ from one consignment to the next. / Los colores de los tejidos y polipiellos pueden variar de una partida a otra. / Les couleurs des tissus, des cuirs synthétiques et des cuirs, ils peuvent varier d'une commande à une autre.



FABRICS / TEJIDOS / TISSUS

Beltá & Frajumar work with the main manufacturers of specific fabrics for home and contract. Some of the most common are indicated hereafter. Should you need fabrics from another manufacturer, please consult us, we will get it.

Beltá & Frajumar trabaja con las principales firmas de tejidos de hogar e instalaciones. Algunas de las más habituales se las detallamos a continuación, si desea trabajar con un tejido de una firma diferente, consúltenos y se lo facilitaremos.

Beltá & Frajumar travaille avec les principaux fournisseurs de tissus domestiques et projets contract. À continuation, nous vous détaillons certain des plus habituels. Si vous désirez travailler avec un tissu d'un fournisseur différent, merci de nous consulter et nous l'informerons s'il est possible.



SUPPLIER PROVEEDOR FOURNISSEUR	COLLECTION SERIE COLECCIÓN SERIE	SUPPLIER PROVEEDOR FOURNISSEUR	COLLECTION SERIE COLECCIÓN SERIE	SUPPLIER PROVEEDOR FOURNISSEUR	COLLECTION SERIE COLECCIÓN SERIE
FABRICS / TELAS / TISSUS					
DESIGNERS GUILD	BRERA LINO s-4 ARNO S-4 HETTON S-3 MEZZOLA S-2 RIVEAU S-4 AUSKERRY S-3 GLENVILLE S-4 KINTORE S-3 ROTHESAY S-4 ZARAGOZA S-3	KVADRAT	REVIVE 1/2 s-5 PAUSE 4 s-5 CAVA 3 s-5 FIELD s-5 MESSENGER 4 s-5	MARIANO FARRUGIA	SAVANA  DALMATA  ANTIQU COLONIAL 
CREVIN	LIBRA s-2 DUO s-2 DAS s-2 MIRO s-3 GAUDÍ s-3 CLUB s-3 MIRAGE s-3	VESCOM	CRES s-4 LOMBOC s-5 SAMAR s-4 NADI s-5	SPRADLING	VALENCIA s-3 SILVERTEX s-4 VOGUE s-4 DOLCE s-5
FROCA	HARRIER s-1 MASTIFF s-1 NILO s-2	GÜELL LA MADRID LE - CREATIONS	FACE s-3 BRIAN s-4 MAC s-4	ALONSO MERCADER	STAR s-2 MAXIUM s-3 RX s-2 FLOR s-2
		SUNBRELLA	NATTÉ s-4 SOLIDS s-3 SATIN s-3		
		VISUAL TEXTURES	BOOK 16 s-2 MYSTIC s-2		
		ATHENEA	ZELDA s-2 LOIRA s-2		

Colours of fabrics and Eco Leather may vary from different lot productions. / Los colores de los tejidos y polipielles pueden variar de una partida a otra. / Les couleurs des tissus et similicuir peuvent être différents d'un métrage à un autre.

WOOD / MADERA / BOIS

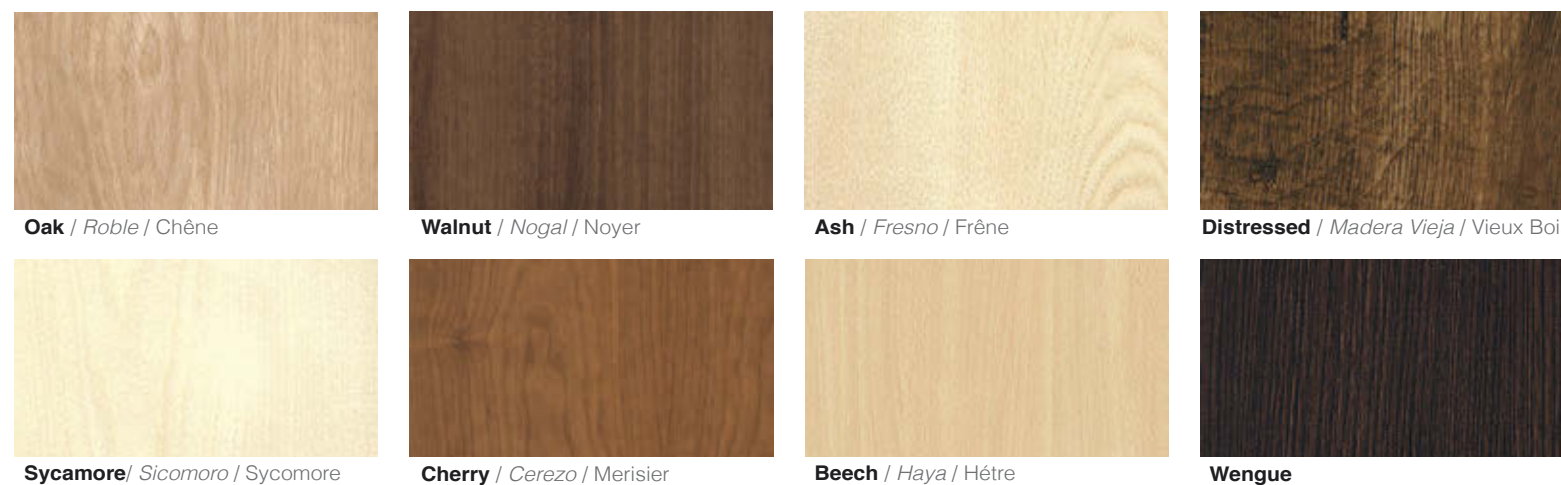

LACQUERED / LACADO / LAQUE

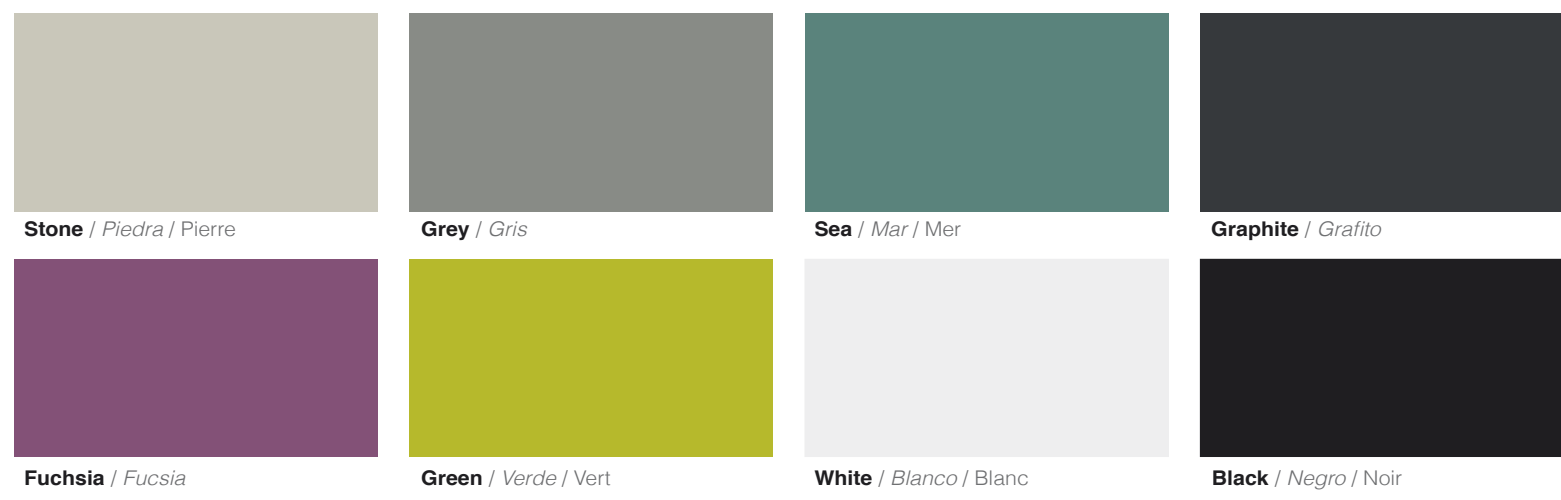

METAL / METAL / MÉTAL



SPECIAL / ESPECIALES / SPÉCIAL

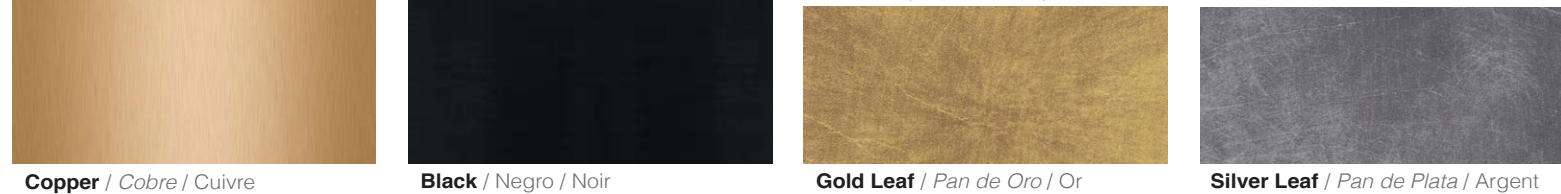

GLASS / CRISTAL / VERRE



MARBLE / MÁRMOL / MARBRE



Thanks to all the professionals that did this project become a reality.

*Gracias a todos los profesionales que han hecho realidad este proyecto.*

Merci a tous les professionnels qui ont fait ce projet réalité.



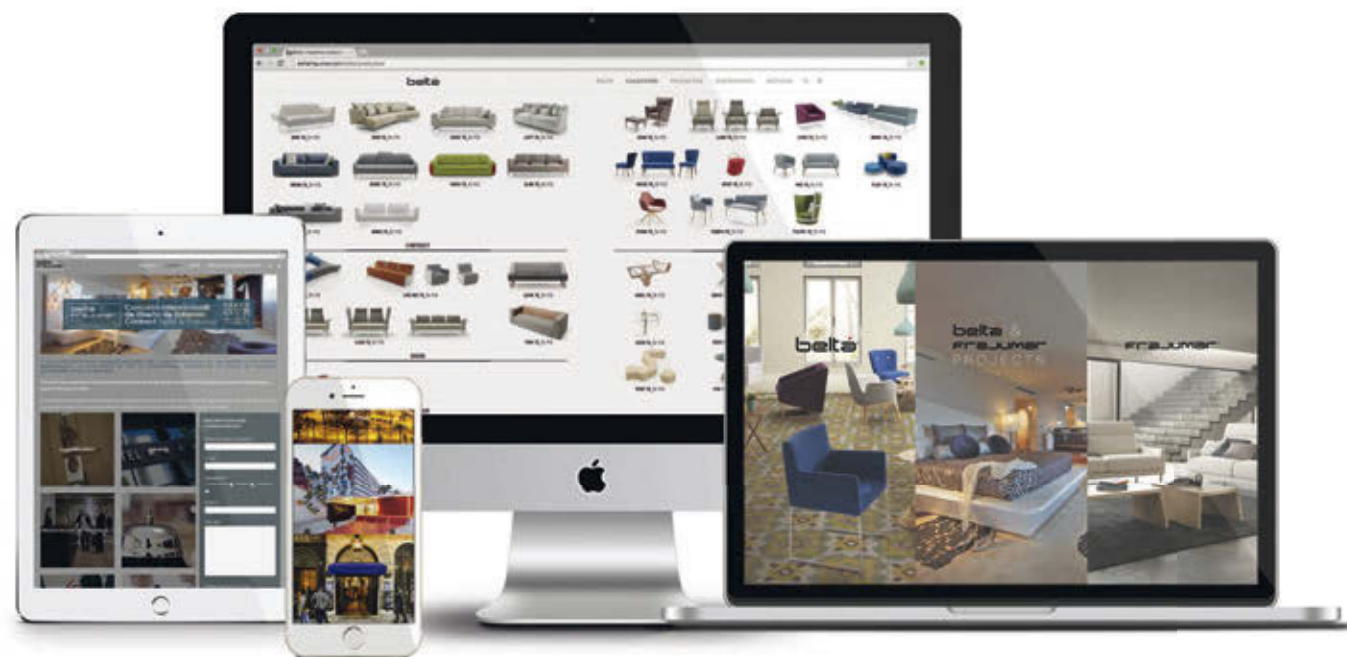

[www.beltafracjumar.com](http://www.beltafracjumar.com)

### Need more info?

All the information you need:

- .Novelties
- .Price lists
- .HR images
- .Technical info
- .3D and 2D files
- .Quality certificates
- .Environmental certificates

### ¿Quieres más?

*La información que necesitas:*

- .Novedades.*
- .Tarifas.*
- .Imágenes HD.*
- .Información técnica.*
- .Archivos 3D y 2D*
- .Certificados de Calidad.*
- .Certificado Medioambiental.*

### Voulez-vous plus d'information?

Voilà tout ce que vous avez besoin:





- .Nouveautés.
- .Tarifs.
- .Images HD.
- .Information technique.
- .Fichiers 3D et 2D
- .Certificats de Qualité.
- .Certificat Environnemental.





Poeta Francisco Antonio Gimenez, 33  
30510, Yecla, Murcia, Spain  
T: +34 968 719111  
F: +34 968 753690

[info@beltafrajumar.com](mailto:info@beltafrajumar.com)  
[www.beltafrajumar.com](http://www.beltafrajumar.com)  
[www.belta.es](http://www.belta.es)  
[www.frajumar.com](http://www.frajumar.com)

 FRAJUMAR Home Contract / BELTÁ Home Contract  
 @belta\_frajumar  
 BELTÁ-FRAJUMAR's channel  
 Pinterest

